Special Licensing Sub Committee

THURSDAY, 8TH NOVEMBER, 2012 at 19:00 HRS - CIVIC CENTRE, HIGH ROAD, WOOD GREEN, N22 8LE.

MEMBERS: Councillors Brabazon, Ejiofor and Reid

AGENDA

- 1. ELECTION OF CHAIR**
- 2. APOLOGIES FOR ABSENCE**
- 3. URGENT BUSINESS**

It being a special meeting of the Sub Committee, under Part Four, Section B, Paragraph 17, of the Council's Constitution, no other business shall be considered at the meeting.

- 4. DECLARATIONS OF INTEREST**

A member with a disclosable pecuniary interest or a prejudicial interest in a matter who attends a meeting of the authority at which the matter is considered:

- (i) must disclose the interest at the start of the meeting or when the interest becomes apparent, and
- (ii) may not participate in any discussion or vote on the matter and must withdraw from the meeting room.

A member who discloses at a meeting a disclosable pecuniary interest which is not registered in the Register of Members' Interests or the subject of a pending notification must notify the Monitoring Officer of the interest within 28 days of the disclosure.

Disclosable pecuniary interests, personal interests and prejudicial interests are defined at Paragraphs 5-7 and Appendix A of the Members' Code of Conduct.

5. SUMMARY OF PROCEDURE (PAGES 1 - 2)

The Chair will explain the procedure that the Committee will follow for the hearing considered under the Licensing Act 2003. A copy of the procedure is attached.

6. MARKFIELD ARTS LTD, 100-108 MARKFIELD ROAD, N15 4QF (PAGES 3 - 270)

To consider an application to allow Supply of Alcohol, Provision of Regulated Entertainment, Provision of Plays, Films, Provision of Live Music, Recorded Music, Performances of Dance, Provision of Facilities for Making Music and Dancing, The Provision of Late Night Refreshment.

Please note that, it being a special meeting of the Sub Committee, under Part Four, Section B, Paragraph 17, of the Council's Constitution, no other business shall be considered at the meeting.

David McNulty
Head of Local Democracy and Member Services
5th Floor
River Park House
225 High Road
Wood Green
London N22 8HQ

Helen Chapman
Principal Committee Coordinator
Tel: 020 8489 2615
Fax: 020 8489 5218
Email: helen.chapman@haringey.gov.uk

Wednesday, 31 October 2012

LICENSING SUB-COMMITTEE HEARINGS PROCEDURE SUMMARY	
INTRODUCTION	
1.	The Chair introduces himself and invites other Members, Council officers, Police, Applicant and Objectors to do the same.
2.	The Chair invites Members to disclose any prior contacts (before the hearing) with the parties or representations received by them
3.	The Chair explains the procedure to be followed by reference to this summary which will be distributed.
NON-ATTENDANCE BY PARTY OR PARTIES	
4.	If one or both of the parties fails to attend, the Chair decides whether to:
	(i) grant an adjournment to another date, or
	(ii) proceed in the absence of the non-attending party.
	Normally, an absent party will be given one further chance to attend.
TOPIC HEADINGS	
5.	The Chair suggests the "topic headings" for the hearing. In the case of the majority of applications for variation of hours, or other terms and conditions, the main topic is:
	Whether the extensions of hours etc. applied for would conflict with the four licensing objectives i.e.
	(i) the prevention of crime and disorder,
	(ii) public safety,
	(iii) the prevention of public nuisance, and
	(iv) the protection of children from harm.
6.	The Chair invites comments from the parties on the suggested topic headings and decides whether to confirm or vary them.
WITNESSES	
7.	The Chair asks whether there are any requests by a party to call a witness and decides any such request.
8.	Only if a witness is to be called, the Chair then asks if there is a request by an opposing party to "cross-examine" the witness. The Chair then decides any such request.
DOCUMENTARY EVIDENCE	
9.	The Chair asks whether there are any requests by any party to introduce late documentary evidence.
10.	If so, the Chair will ask the other party if they object to the admission of the late documents.
11.	If the other party do object to the admission of documents which have only been produced by the first party at the hearing, then the documents shall not be admitted.

12.	If the other party object to documents produced late but before the hearing, the following criteria shall be taken into account when the Chair decides whether or not to admit the late documents:	
(i)	What is the reason for the documents being late?	
(ii)	Will the other party be unfairly taken by surprise by the late documents?	
(iii)	Will the party seeking to admit late documents be put at a major disadvantage if admission of the documents is refused?	
(iv)	Is the late evidence really important?	
(v)	Would it be better and fairer to adjourn to a later date?	
THE LICENSING OFFICER'S INTRODUCTION		
13.	The Licensing Officer introduces the report explaining, for example, the existing hours, the hours applied for and the comments of the other Council Services or outside official bodies. This should be as "neutral" as possible between the parties.	
14.	The Licensing Officer can be questioned by Members and then by the parties.	
THE HEARING		
15.	This takes the form of a discussion led by the Chair. The Chair can vary the order as appropriate but it should include:	
(i)	an introduction by the Objectors' main representative	
(ii)	an introduction by the Applicant or representative	
(iii)	questions put by Members to the Objectors	
(iv)	questions put by Members to the Applicant	
(v)	questions put by the Objectors to the Applicant	
(vi)	questions put by the Applicant to the Objectors	
CLOSING ADRESSES		
16.	The Chair asks each party how much time is needed for their closing address, if they need to make one.	
17.	Generally, the Objectors make their closing address before the Applicant who has the right to the final closing address.	
THE DECISION		
18.	Members retire with the Committee Clerk and legal representative to consider their decision including the imposition of conditions.	
19.	The decision is put in writing and read out in public by the Committee Clerk once Members have returned to the meeting.	

Licensing Act 2003 Sub-Committee on 8th November 2012

Report title: Application for a New Premises Licence at MARKFIELD ARTS LTD, 100-108 MARKFIELD ROAD, LONDON N15 4QF

Report of: Licensing Team Leader

Ward(s) affected Tottenham Green

1. Purpose

To consider an application by Abishek Beltharia allow Supply of Alcohol, Provision of Regulated Entertainment Provision of Plays, Films, Provision of Live Music, Recorded Music, Performances of Dance, Provision of Facilities for Making Music and Dancing, The Provision of Late Nigh Refreshment.

2. Recommendations

- 2.1**
- (a) Grant the application as asked
 - (b) Modify the conditions of the licence, by altering or omitting or adding to them
 - (c) Reject the whole or part of the application

The Committee is asked to note that it may not modify the conditions or reject the whole or part of the application unless it is necessary to promote the licensing objectives.

Report authorised by: Joan Hancox

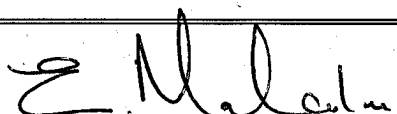

Head of Neighbourhood Services

Contact Officer: Ms Daliah Barrett-Williams

Telephone: 020 8489 8232

3. Executive summary

For consideration by Licensing Sub Committee under Licensing Act 2003 for a Premises licence with variation to the existing conditions

4. Access to information:

Local Government (Access to Information) Act 1985

Background Papers

The following Background Papers are used in the preparation of this Report:

File: Markfield Arts Ltd

The Background Papers are located at Enforcement Service, Technopark, Ashley Road, Tottenham N17

This page is intentionally left blank

5. REPORT**Background**

5.1 An application for a new Premises Licence, by Abishek Beltharia in respect of Markfield Arts Ltd, 100-108 Markfield Road, London N15 4QF under the Licensing Act 2003.

5.2 Details of the application being sought under the Premises Licence—Appendix 1**Provision of Regulated Entertainment: Plays**

Wednesday to Thursday	1700 to 0200 hours
Friday to Saturday	1700 to 0200 hours
Sunday to Monday	1700 to 0300 hours

Bank Holidays: to be operating 24 hours.

Films:

Monday to Thursday	0900 to 0000 hours
--------------------	--------------------

Bank Holidays: to be operating 24 hours

Provision of Live Music

Wednesday to Thursday	1700 to 0200 hours
Friday to Saturday	1800 to 0630 hours
Saturday to Sunday	2100 to 1000 hours
Sunday to Monday	1200 to 0300 hours

Bank Holidays: to be operating 24 hours.

Recorded Music, Performances of Dance, Provision of Facilities for Dancing

Wednesday to Thursday	1800 to 0200 hours
Friday to Saturday	1800 to 0630 hours
Saturday to Sunday	2000 to 1000 hours
Sunday to Monday	1200 to 0300 hours

Bank Holidays: to be operating 24 hours.

Provision of Facilities for Making Music

Monday to Thursday	1000 to 2400 hours
--------------------	--------------------

Bank Holidays: to be operating 24 hours

Provision of Late Night Refreshment

Wednesday to Thursday	2300 to 0200 hours
Friday to Saturday	2300 to 0200 hours
Saturday to Sunday	2300 to 0500 hours
Sunday to Monday	2300 to 0300 hours

Bank Holidays: to be operating 24 hours.

Supply of Alcohol

Wednesday to Thursday	1700 to 0000 hours
Friday to Saturday	1800 to 0700 hours
Saturday to Sunday	2100 to 1000 hours
Sunday to Monday	1200 to 0230 hours

Bank Holidays: to be operating 24 hours.

For consumption **ON** the premises

Hours open to the public

Monday to Wednesday	0900 to 0000 hours
Thursday to Friday	0900 to 0200 hours
Friday to Saturday	1800 to 0700 hours
Saturday to Sunday	2100 to 1000 hours
Sunday to Monday	1200 to 0300 hours

Bank Holidays: to be operating 24 hours.

General-all four licensing objectives

To aid the prevention of Crime and Disorder

- Qualified professional SIA security at a ratio of 1 to 100 will be on site when open to the public.
- CCTV will be employed
- The capacity is for up to 930 people.
- 3 Toilets are in the premises portable toilets will be used 10 units +16 bay urinals at maximum capacity.

Public Safety

- Continuing assessments will be made of all potential hazards referencing HSE guidance.

The Prevention of Public Nuisance

- In order to prevent public nuisance Markfield Arts Ltd will conduct an assessment of the potential sources of nuisance and will implement a sound management plan that will include a complaints line that has been distributed to local residence.

The prevention of Children from Harm

- To gain access to the premises a wristband must be obtained from the box office. Box office staff will be briefed in the admissions policy and people will be first checked for age of identification on 18+ only events.
- Challenge 21 posters will be on display at the box office and at bars, and they say "If you are lucky enough to look under twenty five you will be asked to prove that you are over 18.

5.3 Crime and Disorder

- Measures will be adopted to ensure an event is well organised and internally policed by qualified professional security (SIA).
- All measures are based on intelligence from previous successful events. Markfield Arts fully intend to develop their plans with consultation with Police & Council.
- Adequate SIA personal will be employed for the premises.
- CCTV will be in operation

Drugs Policy

- The premises site will not tolerate illegal drugs.
- Individuals will be searched on entry by SIA staff.
- Any persons deemed to be selling drugs would be detained and handed to the Authorities.
- Illegal drugs will be confiscated, and handed over to Authorities.
- Seizure records will be maintained by security.

5.4 Public Safety

Continuing assessments will be made of the potential hazards involved in

- Site Suitability
- Access and exit links
- Movement of vehicles
- Safe loading and manual handling
- Production area and safety and procedures
- Safe rendezvous points/ emergency areas
- Food Hygiene and standards
- Drinking water
- Competency of contractors
- Security provision
- Stewarding levels
- Waste disposal
- Sanitary provision

There will be a no glass policy.

5.5 Public Nuisance

- Crowd control barriers will be used inside the front enclosure of the premises.
- Signage will be prominently on display reminding patrons to be quiet when leaving the area and to be mindful of respecting the local community.
- The smoking area will be monitored by security/stewards to reduce noise from patrons signage will be employed.
- Most events in the premises will have amplified sound. Consideration will be given to the location of the systems in the premises in relation to the location of the nearest residential properties.
- Noise Limiting devices will be installed in the premises.
- The premises will have sound proofing installed.

In order to prevent public nuisance Markfield Arts Ltd will conduct an assessment of the potential sources of nuisance and will implement the following measures;

- Sound management plan
- Traffic management plan
- Internal Communication
- Complaints procedure
- Signage

5.6 Child Protection

- Activities involving children and young people under the age of 18 will be free of any supply of alcohol.
- Security personnel to challenge patrons they suspect of being under 18 on 18+ events at points of entry.
- All people instructing or directly engaging with children will have an enhanced CRB check.

5.8 Introduction

See App 1A

5.9 Fire Risk Assessment

See App 1B

5.10 Operation Manual

See App 1C

6. RELEVANT REPRESENTATIONS (CONSULTATION)

Responsible authorities:

6.1 Comments of Metropolitan Police

Have made representation regarding this application **Appendix 2**

6.2 Comments of Regulatory Services:**Environmental Health**

Have made representation regarding this application. **Appendix 3**

Trading Standards

Have made no representation to this application.

Building Control

Have made representation to this application based on the fact that they are of the opinion that the applicant has not adequately addressed all the intended usage of the venue in the documentation. They are therefore unable to assess the application as it currently stands. **Appendix 4**

6.3 London Fire and Civil Defence Authority

Have made representation to this application. **Appendix 5**

6.4 Planning Services

Have made no representation to this application. However, Planning Development Control advise that an application was refused and is currently being appealed at The Planning Inspectorate. **Appendix 6**

6.5 Comments of Child Protection Agency or Nominee

No representation made on this matter.

7.0 Interested Parties – Appendix 7

Various letters of representation have been received against this application. Some from other businesses and from the trade representatives of local businesses as well as residents and Ward Members.

8.0 Licensing Officer comments

The applicants have previously attempted to be granted a premises license but this was refused by the Licensing Sub Committee as the clients were unable to meet the public safety objective or the public nuisance objective satisfactorily. The premises has been used for events under the temporary events process but has now reached its limit for the year.

9.0 Financial Comments

The fee which would be applicable for this application was **£190.00**.

APPENDIX 1 – APPLICATION



London Borough of Haringey
Application for a premises licence
Licensing Act 2003

For help contact
Licensing@haringey.gov.uk
 Telephone: 020 8489 8232

* required information

Section 1 of 22

You can save the form at any time and resume it later. You do not need to be logged in when you resume.

System reference

123868

This is the unique reference for this application generated by the system.

Your reference

MARKFIELD ARTS LTD

You can put what you want here to help you track applications if you make lots of them. It is passed to the authority.

Are you an agent acting on behalf of the applicant?

Yes No

Put "no" if you are applying on your own behalf or on behalf of a business you own or work for.

Applicant Details

* First name

ABHISHEK

* Family name

BELTHARIA

* E-mail

abhi_beltharia@yahoo.com

Main telephone number

+447896993830

Include country code.

Other telephone number

+447710088947

Indicate here if you would prefer not to be contacted by telephone

Are you:

- Applying as a business or organisation, including as a sole trader
 Applying as an individual

A sole trader is a business owned by one person without any special legal structure. Applying as an individual means you are applying so you can be employed, or for some other personal reason, such as following a hobby.

Applicant Business

* Is your business registered in the UK with Companies House?

Yes No

* Registration number

Company Number: 07916106

* Business name

MARKFIELD ARTS LTD

If your business is registered, use its registered name.

* VAT number

- none

Put "none" if you are not registered for VAT.

* Legal status

Private Limited Company

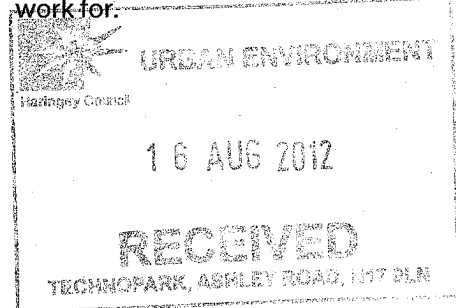

*Continued from previous page...** Your position in the business Home country

The country where the headquarters of your business is located.

Registered Address

Address registered with Companies House.

* Building number or name * Street District * City or town County or administrative area * Postcode * Country

The information given here will be saved and will be pre-filled in future forms.

Section 2 of 22**PREMISES DETAILS**

I/we, as named in section 1, apply for a premises licence under section 17 of the Licensing Act 2003 for the premises described in section 2 below (the premises) and I/we are making this application to you as the relevant licensing authority in accordance with section 12 of the Licensing Act 2003.

Premises Address

Are you able to provide a postal address, OS map reference or description of the premises?

 Address OS map reference Description
Postal Address Of PremisesBuilding number or name Street District City or town County or administrative area Postcode Country **Further Details**Telephone number

Continued from previous page... Non-domestic rateable
value of premises (£)

24,750

Section 3 of 22

APPLICATION DETAILS

In what capacity are you applying for the premises licence?

- An individual or individuals
- A limited company
- A partnership
- An unincorporated association
- A recognised club
- A charity
- The proprietor of an educational establishment
- A health service body
- A person who is registered under part 2 of the Care Standards Act 2000 (c14) in respect of an independent hospital in Wales
- A person who is registered under Chapter 2 of Part 1 of the Health and Social Care Act 2008 in respect of the carrying on of a regulated activity (within the meaning of that Part) in an independent hospital in England
- The chief officer of police of a police force in England and Wales
- Other (for example a statutory corporation)

Confirm The Following

- I am carrying on or proposing to carry on a business which involves the use of the premises for licensable activities
- I am making the application pursuant to a statutory function
- I am making the application pursuant to a function discharged by virtue of Her Majesty's prerogative

Section 4 of 22

NON INDIVIDUAL APPLICANTS

Provide name and registered address of applicant in full. Where appropriate give any registered number. In the case of a partnership or other joint venture (other than a body corporate), give the name and address of each party concerned.

Non Individual Applicant's Name

Name

Continued from previous page...**Details**

Registered number (where applicable)

Description of applicant (for example partnership, company, unincorporated association etc)

Address

Building number or name

Street

District

City or town

County or administrative area

Postcode

Country

Contact Details

E-mail

Telephone number

Other telephone number

Section 5 of 22**OPERATING SCHEDULE**

When do you want the premises licence to start?

 / /

dd

mm

yyyy

If you wish the licence to be valid only for a limited period, when do you want it to end

 / /

dd

mm

yyyy

If 5,000 or more people are expected to attend the premises at any one time, state the number expected to attend

Provide a general description of the premises

Continued from previous page...

For example the type of premises, its general situation and layout and any other information which could be relevant to the licensing objectives. Where your application includes off-supplies of alcohol and you intend to provide a place for consumption of these off- supplies you must include a description of where the place will be and its proximity to the premises.

Please give a general description of the premises (please read guidance note1)
 Markfield Arts is business which involves in manufacturing of Scenery, The Building is also used a space for Private hire for Exhibition, Cultural, Music, Film/Photo Shoot and Dance Event. The Building is completely refurbished single story industrial unit of brick construction .It has emergency exits to front and rear, Non-residential with good loading of production equipment through a large roller shutter
 Good transport links with secure parking.

Section 6 of 22

PROVISION OF PLAYS

Will you be providing plays?

Yes No

Standard Days And Timings

MONDAY

Start

End

Start

End

TUESDAY

Start

End

Start

End

WEDNESDAY

Start

End

Start

End

THURSDAY

Start

End

Start

End

FRIDAY

Start

End

Start

End

SATURDAY

Start

End

Start

End

Give timings in 24 hour clock. (e.g., 16:00) and only give details for the days of the week when you intend the premises to be used for the activity.

Continued from previous page...

SUNDAY

Start

End

Start

End

Will the performance of a play take place indoors or outdoors or both?

- Indoors Outdoors Both

Where taking place in a building or other structure tick as appropriate. Indoors may include a tent.

State type of activity to be authorised, if not already stated, and give relevant further details, for example (but not exclusively) whether or not music will be amplified or unamplified.

AMPLIFIED SOUNDS AND LIGHT INSULATION

State any seasonal variations for performing plays

For example (but not exclusively) where the activity will occur on additional days during the summer months.

Non standard timings. Where the premises will be used for the performance of a play at different times from those listed in the column on the left, list below

For example (but not exclusively), where you wish the activity to go on longer on a particular day e.g. Christmas Eve.

National & Bank Holidays

PLEASE SEE ATTACHED FOR ALL NON-STANDARD TIMINGS FOR UK BANK HOLIDAYS

Section 7 of 22

PROVISION OF FILMS

Will you be providing films?

- Yes No

Standard Days And Timings

MONDAY

Start

End

Start

End

Give timings in 24 hour clock. (e.g., 16:00) and only give details for the days of the week when you intend the premises to be used for the activity.

TUESDAY

Start

End

Start

End

Continued from previous page...

WEDNESDAY

Start	<input type="text" value="09:00"/>	End	<input type="text"/>
Start	<input type="text"/>	End	<input type="text" value="24:00"/>

THURSDAY

Start	<input type="text" value="09:00"/>	End	<input type="text"/>
Start	<input type="text"/>	End	<input type="text" value="24:00"/>

FRIDAY

Start	<input type="text" value="09:00"/>	End	<input type="text"/>
Start	<input type="text"/>	End	<input type="text" value="24:00"/>

SATURDAY

Start	<input type="text" value="09:00"/>	End	<input type="text"/>
Start	<input type="text"/>	End	<input type="text" value="24:00"/>

SUNDAY

Start	<input type="text" value="09:00"/>	End	<input type="text"/>
Start	<input type="text"/>	End	<input type="text" value="24:00"/>

Will the exhibition of films take place indoors or outdoors or both?

- Indoors
 Outdoors
 Both

Where taking place in a building or other structure tick as appropriate. Indoors may include a tent.

State type of activity to be authorised, if not already stated, and give relevant further details, for example (but not exclusively) whether or not music will be amplified or unamplified.

PREVIEW OF ARTIST'S FILMS, DOCUMENTARIES & VISUAL ARTS

State any seasonal variations for the exhibition of film

For example (but not exclusively) where the activity will occur on additional days during the summer months.

Non standard timings. Where the premises will be used for the exhibition of film at different times from those listed in the column on the left, list below

For example (but not exclusively), where you wish the activity to go on longer on a particular day e.g. Christmas Eve.

National & Bank Holidays

Continued from previous page...

Section 8 of 22

PROVISION OF INDOOR SPORTING EVENTS

Will you be providing indoor sporting events?

Yes No

Section 9 of 22

PROVISION OF BOXING OR WRESTLING ENTERTAINMENTS

Will you be providing boxing or wrestling entertainments?

Yes No

Section 10 of 22

PROVISION OF LIVE MUSIC

Will you be providing live music?

Yes No

Standard Days And Timings

MONDAY

Start

End

Start

End

TUESDAY

Start

End

Start

End

WEDNESDAY

Start

End

Start

End

THURSDAY

Start

End

Start

End

FRIDAY

Start

End

Start

End

SATURDAY

Start

End

Start

End

Give timings in 24 hour clock. (e.g., 16:00) and only give details for the days of the week when you intend the premises to be used for the activity.

Continued from previous page...

SUNDAY

Start

End

Start

End

Will the performance of live music take place indoors or outdoors or both?

- Indoors Outdoors Both

Where taking place in a building or other structure tick as appropriate. Indoors may include a tent.

State type of activity to be authorised, if not already stated, and give relevant further details, for example (but not exclusively) whether or not music will be amplified or unamplified.

BAND'S & SHOWCASES INCLUDING AMPLIFIED SOUNDS LIGHTING & PRODUCTION INSTALLATION

State any seasonal variations for the performance of live music

For example (but not exclusively) where the activity will occur on additional days during the summer months.

Non-standard timings. Where the premises will be used for the performance of live music at different times from those listed in the column on the left, list below

For example (but not exclusively), where you wish the activity to go on longer on a particular day e.g. Christmas Eve.

National & Bank Holidays

Section 11 of 22

PROVISION OF RECORDED MUSIC

Will you be providing recorded music?

- Yes No

Standard Days And Timings

MONDAY

Start

End

Start

End

Give timings in 24 hour clock. (e.g., 16:00) and only give details for the days of the week when you intend the premises to be used for the activity.

TUESDAY

Start

End

Start

End

Continued from previous page...

WEDNESDAY

Start	<input type="text" value="18:00"/>	End	<input type="text" value="02:00"/>
Start	<input type="text"/>	End	<input type="text" value=""/>

THURSDAY

Start	<input type="text"/>	End	<input type="text"/>
Start	<input type="text"/>	End	<input type="text"/>

FRIDAY

Start	<input type="text" value="18:00"/>	End	<input type="text" value="07:00"/>
Start	<input type="text" value=""/>	End	<input type="text" value=""/>

SATURDAY

Start	<input type="text" value="20:00"/>	End	<input type="text" value="10:00"/>
Start	<input type="text" value=""/>	End	<input type="text" value=""/>

SUNDAY

Start	<input type="text" value="12:00"/>	End	<input type="text" value="03:00"/>
Start	<input type="text" value=""/>	End	<input type="text" value=""/>

Will the playing of recorded music take place indoors or outdoors or both?

- Indoors
 Outdoors
 Both

Where taking place in a building or other structure tick as appropriate. Indoors may include a tent.

State type of activity to be authorised, if not already stated, and give relevant further details, for example (but not exclusively) whether or not music will be amplified or unamplified.

AMPLIFIED SOUNDS LIGHTING & PRODUCTION INSTALLATIONS

State any seasonal variations for playing recorded music

For example (but not exclusively) where the activity will occur on additional days during the summer months.

Non-standard timings. Where the premises will be used for the playing of recorded music at different times from those listed in the column on the left, list below

For example (but not exclusively), where you wish the activity to go on longer on a particular day e.g. Christmas Eve.

National & Bank Holidays

Continued from previous page...

Section 12 of 22

PROVISION OF PERFORMANCES OF DANCE

Will you be providing performances of dance?

- Yes No

Standard Days And Timings

Give timings in 24 hour clock.
(e.g., 16:00) and only give details for the days
of the week when you intend the premises
to be used for the activity.

MONDAY

Start

End

Start

End

TUESDAY

Start

End

Start

End

WEDNESDAY

Start

End

Start

End

THURSDAY

Start

End

Start

End

FRIDAY

Start

End

Start

End

SATURDAY

Start

End

Start

End

SUNDAY

Start

End

Start

End

Will the performance of dance take place indoors or outdoors or both?

- Indoors Outdoors Both

Where taking place in a building or other
structure tick as appropriate. Indoors may
include a tent.

State type of activity to be authorised, if not already stated, and give relevant further details, for example (but not
exclusively) whether or not music will be amplified or unamplified.

THEIR WILL BE NO DANCES OF SEXUAL NATURE

Continued from previous page...

State any seasonal variations for the performance of dance

For example (but not exclusively) where the activity will occur on additional days during the summer months.

Non-standard timings. Where the premises will be used for the performance of dance at different times from those listed in the column on the left, list below

For example (but not exclusively), where you wish the activity to go on longer on a particular day e.g. Christmas Eve.

National & Bank Holidays

Section 13 of 22

PROVISION OF ANYTHING OF A SIMILAR DESCRIPTION TO LIVE MUSIC, RECORDED MUSIC OR PERFORMANCES OF DANCE

Will you be providing anything similar to live music, recorded music or performances of dance?

- Yes No

Section 14 of 22

PROVISION OF FACILITIES FOR MAKING MUSIC

Will you be providing facilities for making music?

- Yes No

Standard Days And Timings

MONDAY

Start

End

Start

End

Give timings in 24 hour clock. (e.g., 16:00) and only give details for the days of the week when you intend the premises to be used for the activity.

TUESDAY

Start

End

Start

End

WEDNESDAY

Start

End

Start

End

THURSDAY

Start

End

Start

End

Continued from previous page...

FRIDAY

Start

End

Start

End

SATURDAY

Start

End

Start

End

SUNDAY

Start

End

Start

End

Give a description of the type of facilities for making music that will be provided

THE MAKING OF MUSIC WILL BE CONFINED WITH PROPER ACOUSTIC MANAGEMENT TO AVOID ANY SOUND SPILL INTO OR OUTSIDE THE BUILDING. MOBILE RECORDING FACILITIES, BAND'S REHEARSAL FACILITIES

Will the facilities for making music be indoors or outdoors or both?

- Indoors Outdoors Both

Where taking place in a building or other structure tick as appropriate. Indoors may include a tent.

State type of activity to be authorised, if not already stated, and give relevant further details, for example (but not exclusively) whether or not music will be amplified or unamplified.

State any seasonal variations for the provision of facilities for making music

For example (but not exclusively) where the activity will occur on additional days during the summer months.

Non-standard timings. Where the premises will be used for the provision of facilities for making music at different times from those listed in the column on the left, list below

For example (but not exclusively), where you wish the activity to go on longer on a particular day e.g. Christmas Eve.

Section 15 of 22

PROVISION OF FACILITIES FOR DANCING

Continued from previous page...

Will you be providing facilities for dancing?

Yes No

Standard Days And Timings

MONDAY

Start

End

Start

End

TUESDAY

Start

End

Start

End

WEDNESDAY

Start

End

Start

End

THURSDAY

Start

End

Start

End

FRIDAY

Start

End

Start

End

SATURDAY

Start

End

Start

End

SUNDAY

Start

End

Start

End

Give timings in 24 hour clock.
(e.g., 16:00) and only give details for the days
of the week when you intend the premises
to be used for the activity.

Give a description of the type of facilities for dancing that will be provided

Will the facilities for dancing be indoors or outdoors or both?

Indoors Outdoors Both

Where taking place in a building or other
structure tick as appropriate. Indoors may
include a tent.

State type of activity to be authorised, if not already stated, and give relevant further details, for example (but not
exclusively) whether or not music will be amplified or unamplified.

AMPLIFIED SOUND, LIGHTING AND PRODUCTION INSTALLATION

Continued from previous page...

State any seasonal variations for the provision of dancing facilities

For example (but not exclusively) where the activity will occur on additional days during the summer months.

Non standard timings. Where the premises will be used for the performance of a play at different times from those listed in the column on the left, list below

For example (but not exclusively), where you wish the activity to go on longer on a particular day e.g. Christmas Eve.

NATIONAL HOLIDAYS & BANK HOLIDAYS

Section 16 of 22

PROVISION OF FACILITIES FOR ENTERTAINMENT OF A SIMILAR DESCRIPTION TO THOSE PROVIDED FOR MAKING MUSIC OR DANCING

Will you be providing facilities similar in nature to those provided for making music or dancing?

- Yes No

Section 17 of 22

LATE NIGHT REFRESHMENT

Will you be providing late night refreshment?

- Yes No

Standard Days And Timings

MONDAY

Start

End

Start

End

TUESDAY

Start

End

Start

End

WEDNESDAY

Start

End

Start

End

Give timings in 24 hour clock. (e.g., 16:00) and only give details for the days of the week when you intend the premises to be used for the activity.

Continued from previous page...

THURSDAY

Start

End

Start

End

FRIDAY

Start

End

Start

End

SATURDAY

Start

End

Start

End

SUNDAY

Start

End

Start

End

Will the provision of late night refreshment take place indoors or outdoors or both?

- Indoors Outdoors Both

Where taking place in a building or other structure tick as appropriate. Indoors may include a tent.

State type of activity to be authorised, if not already stated, and give relevant further details, for example (but not exclusively) whether or not music will be amplified or unamplified.

TEA, COFFEE, CAKES, SNACKS LIGHT REFRESHMENTS

State any seasonal variations

For example (but not exclusively) where the activity will occur on additional days during the summer months.

Non-standard timings. Where the premises will be used for the supply of late night refreshments at different times from those listed in the column on the left, list below

For example (but not exclusively), where you wish the activity to go on longer on a particular day e.g. Christmas Eve.

Section 18 of 22

SUPPLY OF ALCOHOL

Continued from previous page...

Will you be selling or supplying alcohol?

- Yes No

Standard Days And Timings

MONDAY

Start

End

Start

End

TUESDAY

Start

End

Start

End

WEDNESDAY

Start

End

Start

End

THURSDAY

Start

End

Start

End

FRIDAY

Start

End

Start

End

SATURDAY

Start

End

Start

End

SUNDAY

Start

End

Start

End

Give timings in 24 hour clock.
(e.g., 16:00) and only give details for the days
of the week when you intend the premises
to be used for the activity.

Will the sale of alcohol be for consumption:

- On the premises Off the premises Both

If the sale of alcohol is for consumption on
the premises select on, if the sale of alcohol
is for consumption away from the premises
select off. If the sale of alcohol is for
consumption on the premises and away
from the premises select both.

State any seasonal variations

For example (but not exclusively) where the activity will occur on additional days during the summer months.

Continued from previous page...

Non-standard timings. Where the premises will be used for the supply of alcohol at different times from those listed in the column on the left, list below

For example (but not exclusively), where you wish the activity to go on longer on a particular day e.g. Christmas Eve.

National & Bank Hoildays

State the name and details of the individual whom you wish to specify on the licence as premises supervisor

Name

First name

Abhishek

Family name

Beltharia

Enter the contact's address

Building number or name

47

Street

Springfield Road

District

City or town

London

County or administrative area

Postcode

CR78DZ

Country

United Kingdom

Personal Licence number
(if known)

12/00099/LIPERS

Issuing licensing authority
(if known)

Croydon Council

PROPOSED DESIGNATED PREMISES SUPERVISOR CONSENT

How will the consent form of the proposed designated premises supervisor be supplied to the authority?

- Electronically, by the proposed designated premises supervisor
- As an attachment to this application

Reference number for consent
form (if known)

If the consent form is already submitted, ask the proposed designated premises supervisor for its 'system reference' or 'your reference'.

Section 19 of 22**ADULT ENTERTAINMENT**

Continued from previous page...

Highlight any adult entertainment or services, activities, or other entertainment or matters ancillary to the use of the premises that may give rise to concern in respect of children

Give information about anything intended to occur at the premises or ancillary to the use of the premises which may give rise to concern in respect of children, regardless of whether you intend children to have access to the premises, for example (but not exclusively) nudity or semi-nudity, films for restricted age groups etc gambling machines etc.

THERE ARE NO PLANS OR PROVISIONS FOR ENTERTAINMENT THAT IS OF ADULT OR SEXUAL NATURE.THERE ARE NO PLANS OR PROVISION FOR GAMBLING OF ANY KIND

Section 20 of 22

HOURS PREMISES ARE OPEN TO THE PUBLIC

Standard Days And Timings

MONDAY

Start
Start

End
End

Give timings in 24 hour clock. (e.g., 16:00) and only give details for the days of the week when you intend the premises to be used for the activity.

TUESDAY

Start
Start

End
End

WEDNESDAY

Start
~~Start~~
Start

End
~~End~~
End

THURSDAY

Start
~~Start~~
Start

End
~~End~~
End

FRIDAY

Start
Start

End
End

SATURDAY

Start
Start

End
End

SUNDAY

Start
Start

End
End

State any seasonal variations

For example (but not exclusively) where the activity will occur on additional days during the summer months.

Continued from previous page...

Non standard timings. Where you intend to use the premises to be open to the members and guests at different times from those listed in the column on the left, list below

For example (but not exclusively), where you wish the activity to go on longer on a particular day e.g. Christmas Eve.

National & Bank Holidays

Section 21 of 22

LICENSING OBJECTIVES

Describe the steps you intend to take to promote the four licensing objectives:

a) General – all four licensing objectives (b,c,d,e)

List here steps you will take to promote all four licensing objectives together.

To aid in the prevention of crime and disorder

Qualified professional SIA security at a ratio of 1 to 100 will be on site when open to the public

CCTV will be employed

The capacity is for up to 930 people

3 toilets are in the premises Portable toilets will be used 10 units + 1 6bay urinals at maximum capacity

Public Safety

Continuing Assessments will be made of all potential hazards referencing HSE guidance

The prevention of public nuisance

In order to prevent public nuisance Markfield Arts Ltd will conduct an assessment of the potential sources of nuisance and will implement a sound management plan that will include a complaints line that has been distributed to local residence

The prevention of children from harm

To gain access to the premises a wristband must be obtained from the box office. Box office staff will be briefed in the admissions policy and people will be first checked for age identification on 18+ only events

- Challenge 21 posters will be on display at the box office and at bars, and they say

- "If you are lucky enough to look under twenty five you will be asked to prove that you are over 18.

b) The prevention of crime and disorder

Measures will be adopted to ensure an event is well organised and internally policed by qualified professional security (SIA).

All measures are based on intelligence from previous successful events. Markfield Arts fully intend to develop their plans with consultation with the Police & Council.

Adequate SIA personal will be employed for the premises

CCTV will be in operation

DRUGS POLICY

The premises site will not tolerate illegal drugs.

Individuals will be searched on entry by SIA staff

Any persons deemed to be selling drugs would be detained and handed to the authorities.

Illegal drugs will be confiscated, and handed over to the authorities.

Seizure records will be maintained by security

Continued from previous page...

Signage will be on prominent display, drugs policy and drink-aware

c) Public safety

Continuing Assessments will be made of the potential hazards involved in

- Site suitability
- Access and exits
- Transport links
- Movement of vehicles
- Safe loading and manual handling
- Production area safety and procedures
- Safe rendezvous points/emergency areas
- Food hygiene and standards
- Drinking water
- Competency of contractors
- Security provision
- Stewarding levels
- Waste disposal
- Sanitary provision

There will be a no glass policy

d) The prevention of public nuisance

Crowd control barriers will be used inside the front enclosure of the premises

Signage will be prominently on display reminding patrons to be quiet when leaving the area and to be mindful of rejecting the local community

The smoking area will be monitored by security/stewards to reduce noise from patrons signage will be employed

Most events in the premises will have amplified sound. Consideration will be given to the location of the systems in the premises in relation to the location of the nearest residential properties.

Noise limiting devices will be installed in the premises

The premises will have sound proofing installed

In order to prevent public nuisance Markfield Arts Ltd will conduct an assessment of the potential sources of nuisance and will implement the following measures;

- Sound management plan
- Traffic management plan
- Waste management plan
- Internal communication
- Complaints procedure
- Signage

e) The protection of children from harm

Activities involving children and young people under the age of 18 will be free of any supply of alcohol

Security personnel to challenge patrons they suspect of being under 18 on 18+ events at points of entry.

All people instructing or directly engaging with children will have an enhanced CRB check.

Section 22 of 22**PAYMENT DETAILS**

This fee must be paid to the authority. If you complete the application online, you must pay it by debit or credit card.

Premises Licence Fees are determined by the non domestic rateable value of the premises.

To find out a premises non domestic rateable value go to the Valuation Office Agency site at <http://www.voa.gov.uk/>

Continued from previous page...

business_rates/index.htm

Band A - No RV to £4300	£100.00
Band B - £4301 to £33000	£190.00
Band C - £33001 to £8700	£315.00
Band D - £87001 to £12500	£450.00*
Band E - £125001 and over	£635.00*

*If the premises rateable value is in Bands D or E and the premises is primarily used for the consumption of alcohol on the premises then you are required to pay a higher fee

Band D - £87001 to £12500	£900.00
Band E - £125001 and over	£1,905.00

There is an exemption from the payment of fees in relation to the provision of regulated entertainment at church halls, chapel halls or premises of a similar nature, village halls, parish or community halls, or other premises of a similar nature. The costs associated with these licences will be met by central Government. If, however, the licence also authorises the use of the premises for the supply of alcohol or the provision of late night refreshment, a fee will be required.

Schools and sixth form colleges are exempt from the fees associated with the authorisation of regulated entertainment where the entertainment is provided by and at the school or college and for the purposes of the school or college.

If you operate a large event you are subject to **ADDITIONAL** fees based upon the number in attendance at any one time

Capacity 5000-9999	£1,000.00
Capacity 10000 -14999	£2,000.00
Capacity 15000-19999	£4,000.00
Capacity 20000-29999	£8,000.00
Capacity 30000-39000	£16,000.00
Capacity 40000-49999	£24,000.00
Capacity 50000-59999	£32,000.00

Continued from previous page...

Capacity 60000-69999	£40,000.00
Capacity 70000-79999	£48,000.00
Capacity 80000-89999	£56,000.00
Capacity 90000 and over	£64,000.00

The following credit or debit cards are accepted in Haringey:

Maestro - Mastercard Debit - Mastercard Credit - Solo - Visa Credit - Visa Debit (formerly Delta) and Visa Electron

We cannot accept liability if payment is refused or declined by the card supplier.

Due to end of day processing, this service will not be available between 10pm and 11pm every weekday evening (Mon- Fri).

Users should note that any payments in process after the 10pm deadline need to be completed by 10.05pm

* Fee amount (£)

190.00

ATTACHMENTS

- Premises plan
- Consent form of premises supervisor

AUTHORITY POSTAL ADDRESS**Address**

Building number or name

Street

District

City or town

County or administrative area

Postcode

Country

DECLARATION

* I/we understand it is an offence, liable on conviction to a fine up to level 5 on the standard scale, under section 158 of the licensing act 2003, to make a false statement in or in connection with this application.

Ticking this box indicates you have read and understood the above declaration

This section should be completed by the applicant, unless you answered "Yes" to the question "Are you an agent acting on behalf of the applicant?"

* Full name

ABHISHEK BELTHARIA

* Capacity

930

Signature	<i>Alex Travis</i>
Date	21 st JULY, 2012
Capacity	930

For joint applications signature of 2nd applicant or 2nd applicant's solicitor or other authorised agent. (please read guidance note 12). If signing on behalf of the applicant please state in what capacity.

Signature	
Date	
Capacity	

Contact name (where not previously given) and postal address for correspondence associated with this application (please read guidance note 13)

Post town		Post code	
Telephone number (if any)			
If you would prefer us to correspond with you by e-mail your e-mail address (optional)			

Notes for Guidance

1. Describe the premises. For example the type of premises, its general situation and layout and any other information which could be relevant to the licensing objectives. Where your application includes off-supplies of alcohol and you intend to provide a place for consumption of these off-supplies you must include a description of where the place will be and its proximity to the premises.
2. Where taking place in a building or other structure please tick as appropriate. Indoors may include a tent.
3. For example the type of activity to be authorised, if not already stated, and give relevant further details, for example (but not exclusively) whether or not music will be amplified or unamplified.
4. For example (but not exclusively), where the activity will occur on additional days during the summer months.
5. For example (but not exclusively), where you wish the activity to go on longer on a particular day e.g. Christmas Eve.
6. Please give timings in 24 hour clock (e.g. 16:00) and only give details for the days of the week when you intend the premises to be used for the activity.
7. If you wish people to be able to consume alcohol on the premises please tick on, if you wish people to be able to purchase alcohol to consume away from the premises please tick off. If you wish people to be able to do both please tick both.

Continued from previous page...

Date (dd/mm/yyyy)

16-08-2012

Add another signatory

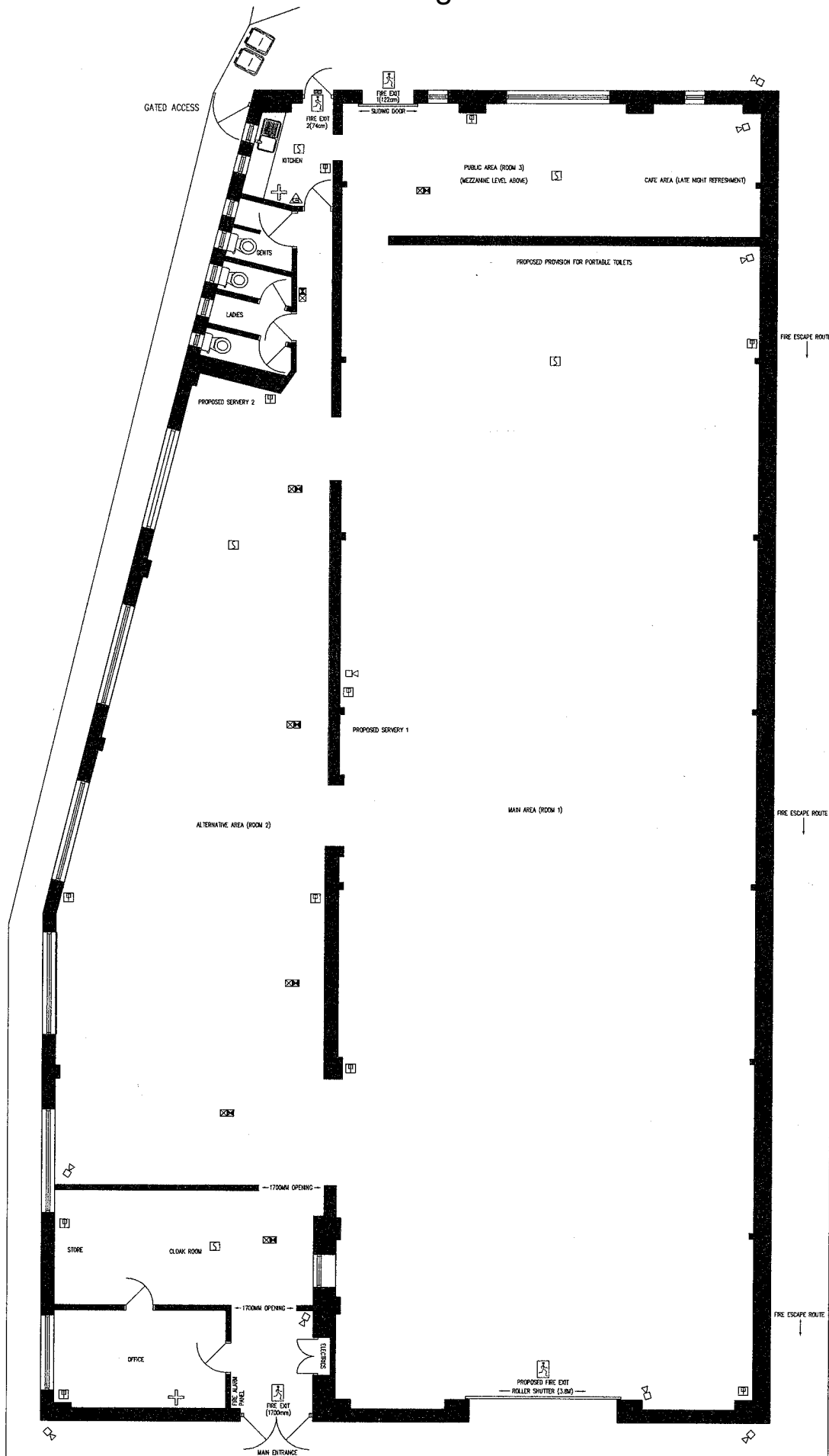

Drawing No: 002519 Rev A	Drawing: Internal Layout	Address: 100-108 Markfield Road, Harringey, London N15 4QF	Date: 11.05.2012	Sheet: 1 of 1
UK Surveyors Ltd CAD Design & Building Surveying Services		☎: Birmingham: 0121 647 4060 ☎: London: 0203 056 7537 ☎: Manchester: 0161 874 7006 ✉: enquiries@uksurveyors.net 🌐: www.uksurveyors.net	Do not scale off this plan	
		Drawn By: DJR	Scale: 1:200 @ A3	

APPENDIX 1A – INTRODUCTION

Address

100-108

Markfield Road

N15 4QF

Company

Markfield Arts Ltd

Company Number 07916106

Registered Office

Suite 17789 Lower ground floor

145-157 St John Street

London EC1 V4PW

INTRODUCTION

The aim is for the space to be versatile and flexible to accommodate a diverse and wide range of activities on the premises :

Exhibitions

Film and photo shoots

Private event hire

Recorded and live music events

Music and theatre production

Workshops in dance, arts and cultures

Indoor Sports and training

Conference and Seminars

Café

Licensed Bar

These risk assessments were carried out with regard to compliance with;

- The Licensing act
- The Health and Safety at work act
- Manual handling regulations
- Control Of Substances Hazardous to Health (COSHH)
- Work at Height regulations
- The provision of work place equipment regulations

Principal Hazards

- Slips and trips
- Working at height
- Manual handling hazards
- Fire safety
- Chemical hazards
- Moving vehicles
- Public order
- Food hygiene and safety standard

<p>Large sums of money on the premises.</p> <p>Bar takings.</p> <p>Site office</p> <p>Banking. Deposits.</p>	<p>Management, stake holders, invested parties. Those responsible for cash on the premises.</p>	<p>H</p>	<p>H</p>	<p>Security/cctv employed to ensure the safety of personnel responsible for cash money on the premises. All cash monies are to be kept in a locked safe until deposited with the bank.</p> <p>No money will be on the premises overnight.</p>	<p>The SIA Security will be trained in close protection and shall provide cover for staff while taking deposits to the bank.</p>	<p>management planning team</p>	<p>Planning stage prior to license application</p>	<p>Low</p>	<p>RESIDUAL RISK</p>
<p>HAZARD Crime and disorder</p>	<p>PERSONS AFFECTED</p>	<p>RISK</p>	<p>SEVERITY</p>	<p>EXISTING CONTROLS</p>	<p>ADDITIONAL CONTROLS</p>	<p>ACTION BY WHOM</p>	<p>ACTION BY WHEN</p>	<p>RESIDUAL RISK</p>	

<p>Robbery and theft.</p> <p>Public Areas</p> <p>Car parks</p>	<p>Clients, Workers, workers from other companies, artists, performers, members of the public.</p>	<p>L</p>	<p>H</p>	<p>Security to provide patrols in the Public areas. Stewards and security to report any incidents to duty site manager at site office. Police to be called if any breach of the law has occurred.</p> <p>Security patrols of Premises.</p> <p>Security patrols in car parking & Smoking areas.</p>	<p>Liaison with local Police authority. Incident log book compiled by a duty site manager and kept at premises office.</p> <p>Policy to be intelligence led.</p>	<p>Management planning team. SIA security.</p>	<p>Planning stage prior to license application.</p>	<p>Low</p>	<p>HAZARD</p>	<p>PERSONS AFFECTED</p>	<p>RISK</p>	<p>SEVERITY</p>	<p>EXISTING CONTROLS</p>	<p>ADDITIONAL CONTROLS</p>	<p>ACTION BY WHOM</p>	<p>ACTION BY WHEN</p>	<p>RESIDUAL RISK</p>
----------------------------------------------------------------	----------------------------------------------------------------------------------------------------	----------	----------	----------------------------------------------------------------------------------------------------------------------------------------------------------------------------------------------------------------------------------------------------------------------------------------------------------------	----------------------------------------------------------------------------------------------------------------------------------------------------------------------	------------------------------------------------	-----------------------------------------------------	------------	---------------	-------------------------	-------------	-----------------	--------------------------	----------------------------	-----------------------	-----------------------	----------------------

<p>Traffic load on the public highway.</p>	<p>Clients, Workers, workers from other companies, artists, performers, members of the public and the wider community.</p>	<p>L</p>	<p>H</p>	<p>Marshaled ingress & egress of traffic.</p>	<p>Internal traffic management system allowing vehicles to be directed off the public highway and into the site traffic and parking system avoiding so far as is reasonably practicable any undue queuing or "bottle necks".</p>	<p>Management planning team.</p>	<p>Planning stage prior to license application.</p>	<p>Low</p>	<p>HAZARD</p>	<p>PERSONS AFFECTED</p>	<p>RISK</p>	<p>SEVERITY</p>	<p>EXISTING CONTROLS</p>	<p>ADDITIONAL CONTROLS</p>	<p>ACTION BY WHOM</p>	<p>ACTION BY WHEN</p>	<p>RESIDUAL RISK</p>
-----------------------------------------------------------	-----------------------------------------------------------------------------------------------------------------------------------------------------------	----------	----------	--------------------------------------------------------------	-------------------------------------------------------------------------------------------------------------------------------------------------------------------------------------------------------------------------------------------------------------------------------------	-------------------------------------------------	--------------------------------------------------------------------	-------------------	----------------------	--------------------------------	--------------------	------------------------	---------------------------------	---------------------------------------	----------------------------------	------------------------------	---------------------------------

<p>Separation of pedestrians and moving vehicles within the premises.</p>	<p>Clients, Workers, workers from other companies, artists, performers, members of the public and the wider community.</p>	<p>L</p>	<p>H</p>	<p>The planning and implementing of an internal traffic management system. Clearly defined traffic routes. Marshaling of traffic.</p>	<p>Barriers to be used to separate pedestrians</p>	<p>Management planning team.</p>	<p>Planning stage prior to license application</p>	<p>Low</p>
<p>HAZARD Public nuisance</p>	<p>PERSONS AFFECTED</p>	<p>RISK</p>	<p>SEVERITY</p>	<p>EXISTING CONTROLS</p>	<p>ADDITIONAL CONTROLS</p>	<p>ACTION BY WHOM</p>	<p>ACTION BY WHEN</p>	<p>RESIDUAL RISK</p>

<p>Unwanted or undue sound output overspill outside from the premises</p>	<p>Members of the public and the wider community.</p>	<p>L</p>	<p>M</p>	<p>Premises Location assessed by a competent sound specialist. Soundproofing to be installed Overall sound output to be monitored at the perimeter of nearest residence to ensure inaudibility by a dedicated team hand held decibel meters to be used inside the premises</p>	<p>Results to be recorded in a log held at the site office and the data used to manage overall sound output. Sound out-put to be managed overall by the duty site manager. A dedicated complaints line will be staffed at all times and distributed to local residents</p>	<p>Management planning team.</p>	<p>Planning stage prior to license application</p>	<p>Low</p>
<p>HAZARD</p>	<p>PERSONS AFFECTED</p>	<p>RISK</p>	<p>SEVERITY</p>	<p>EXISTING CONTROLS</p>	<p>ADDITIONAL CONTROLS</p>	<p>ACTION BY WHOM</p>	<p>ACTION BY WHEN</p>	<p>RESIDUAL RISK</p>

HAZARD Prevention of public nuisance	PERSONS AFFECTED	RISK	SEVERITY	EXISTING CONTROLS	ADDITIONAL CONTROLS	ACTION BY WHOM	ACTION BY WHEN	RESIDUAL RISK
Disorder or disturbance outside the Premises.	Clients, Workers, workers from other companies, artists, performers, members of the public and the wider community.	M	M	Traffic marshals will be deployed.	Planning of premises infrastructure and provision of services.	Management planning team.	Planning stage prior to license application	Low
Parked vehicles on the public highway.		M	M	Signage reminding people to be quiet when queuing and leaving the premises	Planning and implementation of a traffic management plan.			
Late night disturbances outside the Premises		M	M		Planning and implementation of admissions policy.			

<p>Late night refreshment</p>	<p>Clients, Workers, workers from other companies, artists, performers, members of the public and the wider community.</p>	<p>L</p>	<p>L</p>	<p>Bar to close as per license conditions The Café will have Adequate training and supervision for staff</p>	<p>No alcohol is sold or served at the Café</p>	<p>Management planning team.</p>	<p>Planning stage prior to license application</p>	<p>Low</p>
<p>HAZARD Crime and disorder</p>	<p>PERSONS AFFECTED</p>	<p>RISK</p>	<p>SEVERITY</p>	<p>EXISTING CONTROLS</p>	<p>ADDITIONAL CONTROLS</p>	<p>ACTION BY WHOM</p>	<p>ACTION BY WHEN</p>	<p>RESIDUAL RISK</p>

<p>Aggressive or violent behavior</p>	<p>Clients, Workers, workers from other companies, artists, public and the wider community.</p>	<p>L</p>	<p>H</p>	<p>SIA Security provided trained in conflict resolution. City will liaise with security to prevent situations from developing.</p> <p>Entity refused to aggressive or violent people.</p> <p>Police informed of any breach of the Law.</p>	<p>Log book used to record any incident. Liaison with security to prevent situations from developing.</p>	<p>Management planning team.</p>	<p>Planning stage prior to license application</p>	<p>Low</p>
<p>HAZARD</p>	<p>PERSONS AFFECTED</p>	<p>RISK</p>	<p>SEVERITY</p>	<p>EXISTING CONTROLS</p>	<p>ADDITIONAL CONTROLS</p>	<p>ACTION BY WHOM</p>	<p>ACTION BY WHEN</p>	<p>RESIDUAL RISK</p>

<p>Emergency vehicle access.</p>	<p>Clients, Workers, workers from other companies, artists, public safety, members of the public and the wider community.</p>	<p>H</p>	<p>H</p>	<p>Dedicated emergency vehicle access into event</p>	<p>Entrances adequately staffed at all times.</p>	<p>Management planning team.</p>	<p>Planning stage prior to license application</p>	<p>Low</p>	<p>HAZARD</p>	<p>PERSONS AFFECTED</p>	<p>RISK</p>	<p>SEVERITY</p>	<p>EXISTING CONTROLS</p>	<p>ADDITIONAL CONTROLS</p>	<p>ACTION BY WHOM</p>	<p>ACTION BY WHEN</p>	<p>RESIDUAL RISK</p>
---------------------------------------------	--------------------------------------------------------------------------------------------------------------------------------------------------------------	-----------------	-----------------	---------------------------------------------------------------------	--------------------------------------------------------------	-------------------------------------------------	-------------------------------------------------------------------	-------------------	----------------------	--------------------------------	--------------------	------------------------	---------------------------------	---------------------------------------	----------------------------------	------------------------------	---------------------------------

HAZARD	PERSONS AFFECTED	RISK	SEVERITY	EXISTING CONTROLS	ADDITIONAL CONTROLS	ACTION BY WHOM	ACTION BY WHEN	RESIDUAL RISK
<p>Transport links</p>	<p>Clients, Workers, workers from other companies, artists, community, members of the public and the wider community.</p>	<p>L</p>	<p>L</p>	<p>Internal traffic management system competently managed by staff.</p>	<p>Local Private hire companies will be alerted to the availability of increased number of passengers from the station.</p>	<p>Management planning team.</p>	<p>Planning stage prior to license application</p>	<p>Low</p>

<p>Pedestrian emergency exit</p>	<p>Clients, Workers, workers from other companies, artists, members of the public and the wider community.</p>	<p>M</p>	<p>H</p>	<p>Emergency signs to direct the public from the premises to areas</p>	<p>Head count on premises used to verify numbers</p>	<p>Management planning team.</p>	<p>Planning stage prior to license application</p>	<p>Low</p>
<p>HAZARD Public safety</p>	<p>PERSONS AFFECTED</p>	<p>RISK</p>	<p>SEVERITY</p>	<p>EXISTING CONTROLS</p>	<p>ADDITIONAL CONTROLS</p>	<p>ACTION BY WHOM</p>	<p>ACTION BY WHEN</p>	<p>Residual risk</p>

<p>Food hygiene/ safety</p>	<p>Clients, Workers, workers from other communities, artists members of the community</p>	<p>M</p>	<p>H</p>	<p>All food retail outlets are required to provide evidence of compliance of premises prior to the being filled on the premises A current food hygiene certificate Their current HACCAP /food standards agency log A current insurance certificate with the relevant amount of cover Suitable and sufficient risk assessments/method statements.</p>	<p>Pre- event checks by the premises management team</p>	<p>Management planning team</p>	<p>Planning stage prior to license application</p>	<p>Low</p>	<p>Residual risk</p>
<p>HAZARD</p>	<p>PERSONS AFFECTED</p>	<p>RISK</p>	<p>SEVERITY</p>	<p>EXISTING CONTROLS</p>	<p>ADDITIONAL CONTROLS</p>	<p>ACTION BY WHOM</p>	<p>ACTION BY WHEN</p>		

Live Performing Arts	Client Workers, workers from other performing artists	L	H	Performers and tutors relevant to performing arts	Stewards to be in attendance during performance	Management planning	Planning stage prior to license application	Low
HAZARD	PERSONS AFFECTED	RISK	SEVERITY	EXISTING CONTROLS	ADDITIONAL CONTROLS	ACTION BY WHOM	ACTION BY WHEN	Residual risk
				<p>Performers and tutors relevant to performing arts</p> <p>Stewards to be in attendance during performance</p>				

<p>Fire hazards.</p>	<p>Clinets, Workers, workers from other premises participating</p>	<p>L</p>	<p>H</p>	<p>No smoking policy Law compliance Fire extinguishers Fire blankets Fire blankets Suitable and sufficient signage And illuminated indicating emergency escape routes to a place of safety.</p>	<p>Additional fire risk assessment carried out by a competent person Review of the of fire safety arrangements at quarterly Health and safety meeting.</p>	<p>Duty Site manager</p>	<p>At all times. Daily Prior to work commencing.</p>	<p>Low</p>
----------------------	--------------------------------------------------------------------	----------	----------	-------------------------------------------------------------------------------------------------------------------------------------------------------------------------------------------------------------------------	----------------------------------------------------------------------------------------------------------------------------------------------------------------	--------------------------	--------------------------------------------------------------	------------

Disclaimer

The information contained in this document/record is proprietary to the premises unless stated otherwise and is made available in confidence. It must not be used or disclosed without the express written permission of the directors of Markfield Arts Ltd or Prog Ltd. This document/record may not be copied in whole or in part in any form without the express written consent of the above, which may be given by contract.

The contents of this document are subject to change without notice, until the document is approved and agreed by all parties and released at Issue 1.

Date of issue	10th March, 2012
----------------------	------------------------------------



Ria Seven Sisters
unit 10
london

Receipt No. : 004505811
Date: 8/15/2012 18:03
Teller's name: Nicholas Amayo

Agent Information

Agent number	Agent Name	Agent Address
UK277	El Cafetal Services Limited	231 High Road

Memo:
201-3022819

Total: 5,460.00 GBP

Signature

Teller's signature



Ria Seven Sisters
unit 10
london

Receipt No. : 004505811
Date: 8/15/2012 18:03
Teller's name: Nicholas Amayo

Agent Information

Agent number	Agent Name	Agent Address
UK277	El Cafetal Services Limited	231 High Road

Memo:
201-3022819

Total: 5,460.00 GBP

Signature

Teller's signature

Store: Ria Seven Sisters
Receipt No: 004505811
Total: 5,460.00 GBP
Date: 8/15/2012 18:03
Teller: Nicholas Amayo

This page is intentionally left blank

APPENDIX 1B – FIRE RISK ASSESSMENT

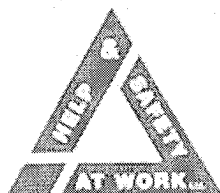

H.A.S.A.W LTD



Head Office
7 Midland Road
Thrapston
Northants
NN14 4JS

Specialists In Fire Protection & Prevention

FIRE RISK ASSESSMENT REPORT

Single site/occupier

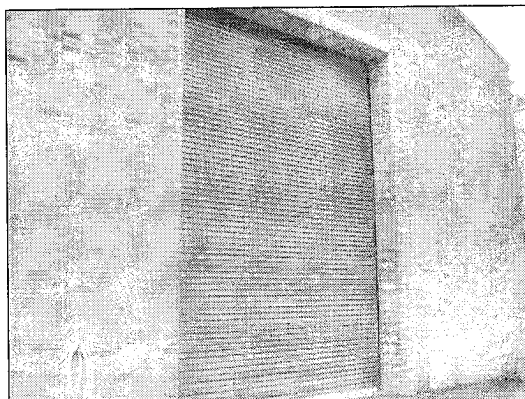

Address of property
Markfield Arts Ltd
100-108 Markfield Rd
London
N14 4QF

Telephone No.
07896-993830

Person responsible for fire safety
Mr Abhi Beltharia

Date of Fire Risk Assessment
25th June 2012

Assessor
Alfred Hake GFireEng

Reference
HS122506

Recommended Next Risk Assessment Review date.

June 2013

This fire risk assessment should be reviewed by the responsible person regularly so as to keep it up to date, and in any event by the date indicated above or at such earlier time as (a) there is reason to suspect that it is no longer valid; or (b) there has been a significant change in the matters to which it relates including when the premises, special, technical and organisational measures, or organisation of the work undergo significant changes, extensions, or conversions.

Scope of Fire Risk Assessment

1. The Regulatory Reform (Fire Safety) Order 2005 (if the relevant premises are in England or Wales) or the Fire (Scotland) Act 2005 (if the relevant premises are in Scotland) require the Employer or other responsible person to carry out a fire safety risk assessment of the premises.

2. This risk assessment carried out is made to enable the Employer or other responsible person to comply with the legal requirements summarised in Paragraph 1 above.

3. This report is addressed to the Employer (or if applicable other responsible person in relation to the premises) for its sole benefit and may not be relied upon by any other person, firm or company.

4. The risk assessment should be available for inspection.

5. This fire risk assessment should be reviewed by the responsible person regularly so as to keep it up-to-date and, in any event by the date indicated on the front page of this report or at such earlier time as (a) there is reason to suspect that it is no longer valid; or (b) there has been a significant change in the matters to which it relates including when the premises, special, technical and organisational measures, or organisation of the work undergo significant changes, extensions, or conversions. By way of example and without limiting the general statement made above, the assessment should be reviewed following:

- a) Significant changes to work practices or procedures.
- b) A significant change in the number of people present or the characteristics of the occupants including the presence of people with some form of disability.
- c) Any significant structural or material changes to the premises (including the internal layout) or to the processes or activities conducted at the premises, including the introduction of new equipment.
- d) Significant changes to furniture and fixings and/or to displays or quantities of stock.
- e) The introduction or increase in the storage of hazardous substances.
- f) Any change in the fire precautions in the premises.
- g) Any near miss or fire incident.

and, in any event, at recommended intervals of no more than twelve months.

6. The hazards and/or risks identified (if any) in each section of this document increase the risk to life and/or property safety in and around the areas assessed.

7. The Employer, or other responsible person, should ensure that the additional fire safety controls, recommendations and actions set out in this document are effected to bring the assessed areas up to a standard that will ensure, so far as is reasonably practicable, the safety of any of his employees, any other person lawfully on the premises or any person in the immediate vicinity of the premises at risk from a fire on the premises.

8. The Regulatory Reform (Fire Safety) Order 2005 and the Fire (Scotland) Act 2005, as applicable, impose various other obligations in relation to fire safety on responsible persons. We would be pleased to provide further guidance on these obligations but would like to draw your particular attention to the following:

Responsible persons must, amongst other things, provide their employees with comprehensive and relevant information on the risks to them identified by the risk assessment, the preventative and protective measures taken and the procedures and measures in place in the event of serious and imminent danger to them.

9. In this report:

- a) Where relevant facts in relation to the premises were not visually apparent on the date of our inspection, we have relied on the information and/or responses provided by or on behalf of the Employer or other responsible person.
- b) We have assumed that all relevant building regulations were complied with in the construction of the premises, including any extension(s), conversion(s), renovation(s) and refurbishment(s).
- c) Unless otherwise stated, we have assumed that at the premises (i) all fire safety equipment, including fire doors and fire resistant partitions and (ii) all servicing of fire safety equipment has been installed or carried out (as the case may be) by persons competent to do so and in accordance with all applicable standards.
- d) We have not looked in roof spaces or other hidden areas in the premises except where there was an obvious fire hazard which reasonably required further investigation.
- e) We have assumed that information and documentation supplied to us by or on behalf of the Employer or other responsible person which has a bearing on this fire risk assessment is current, true, accurate and not misleading.
- f) The term "responsible person" has the meaning given to it in The Regulatory Reform (Fire Safety) Order 2005 [and the Fire (Scotland) Act 2005.

Index of sections *

Section A: General Information.

Section B: Fire Hazards and Ignition Sources.

Section C: Means of Escape in Case of Fire.

Section D: Emergency Escape Lighting.

Section E: Signs and Notices.

Section F: Fire Alarm and Fire Warning Arrangements.

Section G: Fixed and Portable Fire Extinguishing Equipment.

Section H: Management of Fire Safety.

Section I: Access for Fire Fighting and Fire Fighter Safety.

Section J: Schedule of Responsibilities.

Section K: Assessing the Risk.

Section L: Action Plan.

Section M: Premises Risk Categorisation.

Section N: Occupancy Figures

** Please note that in this report certain sections may have been deleted if they are not relevant to your premises*

A: GENERAL INFORMATION**DESCRIPTION OF PROPERTY**

The property is a single storey, purpose built detached warehouse building

Premises risk level at the time of the risk assessment; NORMAL
(See section m)

Number of storeys, including basement floors in the building: 1

Number of storeys included in the risk assessment: 1

Approximate total floor area in M2 of the floors surveyed: 560

Approximate floor area in M2 of the footprint of the building: 560

Number of additional tenants/occupiers in the building: 0

Brief details of Construction:

Modern single storey construction, brick and block work walls with a concrete floor and a corrugated pitched roof

Occupiers Details:

Location of areas assessed i.e. 2 nd floor, common areas etc.	Activity and/or Process	No employed
Ground Floor	Office and public area	25*

USE OF PREMISES

The premises are used as A place of public entertainment

OCCUPIERS OF THE BUILDING

Approximate total numbers of persons employed in the whole premises: 25*

Approximate numbers of members of the public resorting to the premises: 450

Premises used out of hours? Yes

Are persons specifically at risk? No

Approximate total numbers known to sleep in the premises: 0

Disabled occupants? No

Occupants in remote areas? No

Is there any recent history of fires in the building? No

Comments and other relevant issues noted (list)

The premises consist of a single storey brick built, mid to late XX century light industrial unit construction. With three exits, one situated at the front of the building and two at the rear. Furthermore, a roller shutter 3 metres wide is also featured at the front of the premises,
* It should be noted that at the time of inspection no one was employed and the figure of 25 employees is an expected figure subject to local authority licensing

B: FIRE HAZARDS AND IGNITION SOURCES

B1; Electrical Sources of Ignition

- | | |
|---------------------------------------------------------------------------------|-----|
| a. Is portable appliance testing carried out? | Yes |
| b. Are electrical circuits and installations periodically tested and inspected? | Yes |
| c. Is there managerial control of personal electrical items? | Yes |
| d. If extension leads and adaptors are in use are they used safely? | Yes |
| e. Are electrical cables routed so as to avoid physical damage? | Yes |
| f. Is lightning protection provided for the building? | N/A |

Comments and other relevant issues noted (list)

Note: see recommendations in the action plan/recommendations section of this report.

B1, b, Mr Beltharia informed this inspector that PAT and circuit testing is undertaken, however no record of PAT or circuit testing was available at time of inspection

Indicate the appropriate risk level: High

B2; Smoking

- | | |
|----------------------------------------------------------|-----|
| a. Is smoking permitted in any part of the building? | No |
| b. Is smoking managed in an appropriate and safe manner? | N/A |

Comments and other relevant issues noted (list)

Note: see recommendations in the action plan/recommendations section of this report.

B2, No comment required

Indicate the appropriate risk level: Normal

B3; Heating

- a. Are mains gas supplies connected? No
- b. Are fixed heating installations, gas appliances and boilers subject to regular maintenance by competent contractors? N/A
- c. Are portable heaters in use?
list the types; None seen
- d. Are portable heaters kept away from any combustible storage or refuse? N/A

Comments and other relevant issues noted (list)

Note: see recommendations in the action plan/recommendations section of this report.

B3, No gas was seen on site except for a gas meter.

B3, Heating undertaken by an electrically powered industrial blower, No service record available at the time of inspection

Indicate the appropriate risk level: High

B4; Cooking

- a. Are catering facilities provided? Yes

Comments and other relevant issues noted (list)

Note: see recommendations in the action plan/recommendations section of this report.

B4, a, Catering facilities consist solely of drinks making and food warming facilities, which are considered to be part of the electrical risk. No comment required.

Indicate the appropriate risk level: Normal

B5; Arson/Wilful Fire Raising

- a. Is external refuse managed adequately? Yes
- b. Are suitable external security arrangements in place? Yes
- c. Are suitable internal security arrangements in place? Yes
- d. Is the building vulnerable to arson? No

Comments and other relevant issues noted (list)

Note: see recommendations in the action plan/recommendations section of this report.

B5, No comment required

Indicate the appropriate risk level: Normal

B6; Factory Processes

Do any potentially hazardous processes take place? No

Comments and other relevant issues noted (list)

Note: see recommendations in the action plan/recommendations section of this report.
 B6, No comment required

Indicate the appropriate risk level: **Low**

B7; Storage and Housekeeping

- a. Are large/abnormal amounts of combustible storage kept in the premises? Yes
- b. Is there a large or excessive fire loading? Yes
- c. If so are storage arrangements adequate? Yes
- d. Are highly flammable materials kept in the premises? No
- e. If so are storage arrangements adequate? N/A
- f. Are other hazardous materials kept in the premises? No
- g. If so are storage arrangements adequate? No
- h. Is general housekeeping satisfactory? Yes
- i. Is the upholstery of foam furniture in good condition? No
- j. Are significant ignition sources separated from combustible or highly flammable materials? Yes
- k. Is the use of highly flammable materials minimised? Yes

Comments and other relevant issues noted (list)

Note: see recommendations in the action plan/recommendations section of this report.
 B7, a & b, The premises have a considerable amount of fabric wall hangings
 B7, i, Soft furnishings to be checked for fire retardancy

Indicate the appropriate risk level: **High**

B8; Building Work and Outside Contractors

- | | |
|------------------------------------------------------------------------------|-----|
| At the time of the risk assessment, was any building work being carried out? | No |
| a. If so did this introduce any unusual hazards or ignition sources? | N/A |
| b. Is managerial control of contractors adequate and satisfactory? | N/A |
| c. Are any fire safety conditions imposed on contractors? | N/A |
| d. Is there a permit to work/ hot work permits scheme? | N/A |
| e. Do contractors work out of hours? | N/A |

Are occupants at risk from fire hazards and ignition sources, which have been introduced by builders/contractors? N/A

Comments and other relevant issues noted (list)

Note: see recommendations in the action plan/recommendations section of this report.

B8, No comment required

Indicate the appropriate risk level: Low

C: MEANS OF ESCAPE

Main Access to the building is via: a single entrance from the street via a set of double doors

C1; Alternative Means of Escape;

An alternative means of escape is provided.

The alternative means of escape are available via 2 final exit doors

- | | |
|----------------------------------------------------------------------------------|-----|
| a. Are there adequate numbers of final exit doors? | Yes |
| b. Can all fire exits be immediately opened without the use of a key? | No |
| c. Are electronic security locks fitted to exit doors on escape routes? | No |
| d. If so are they appropriately and safely fitted and maintained? | N/A |
| e. Do fire exits open in the direction of escape? | Yes |
| f. Are sliding or revolving doors relied on for means of escape? | Yes |
| g. Is adequate artificial illumination provided where necessary? | Yes |
| h. Are the alternative exit route/s provided with appropriate fire exit signage? | No |

Comments and other relevant issues noted (list)

Note: see recommendations in the action plan/recommendations section of this report.

C1, a, Rear exit door damaged

C1, b & f, A sliding door is designated an escape door which appeared locked at the time of inspection

C1, h, See section 'E' in 'Fire Action Plan'

Indicate the appropriate risk level: High

C2; Protection of Internal Escape Routes and Structural Integrity

- | | |
|-------------------------------------------------------------------------------------------------------------------------|-----|
| a. Are any dead end exit routes adequately protected? | N/A |
| b. Are floor surfaces, stairs and handrails etc, safe? | Yes |
| c. Are exit routes adequately clear of storage and obstructions? | No |
| d. Are staircases kept clear of storage and obstructions? | N/A |
| e. Are existing fire doors installed to conform with British Standard 476? | No |
| f. Are fire doors held open by irregular means? | N/A |
| g. Are door holding devices fitted to fire doors? | N/A |
| h. If so are they appropriately and safely fitted, signed and maintained? | N/A |
| i. Are any fire doors or fire resisting partitions damaged? | No |
| j. Are existing fire resisting partitions installed to comply with British Standard 476 as far as could be ascertained? | Yes |
| k. Is there reasonable limitation of linings which might promote fire spread? | Yes |
| l. Are service shafts between floors adequately fire stopped? | N/A |
| m. Are doors to service riser shafts to a suitable fire resisting standard? | N/A |
| n. Is compartmentation considered to be of a reasonable standard? | N/A |

Comments and other relevant issues noted (list)

Note: see recommendations in the action plan/recommendations section of this report.

C2, c, It was noticed that storage was seen on a unaccessible mezzanine area at the rear of the building situated above the curtain wall

C2, e, Doors to office not up to current fire door standard, additionally the electrical intake cupboard doors adjacent to the general office require to be fire resistant.

Indicate the appropriate risk level: High

C3; External Exit Routes

- a. Do external exit routes lead to a place of final safety? Yes
- b. Are external exit routes even and without obstructions or trip hazards? No
- c. Are external staircases, balconies and gangways examined by a competent person at not less than three yearly intervals. N/A
- d. Are external staircases, balconies and gangways properly and adequately protected from fire in the parent or adjacent occupancy? N/A
- e. Are external exit routes clear of obstructions, storage and refuse? Yes
- f. Are external exit routes considered satisfactory? No

Comments and other relevant issues noted (list)

Note: see recommendations in the action plan/recommendations section of this report.

C3, b & f, The escape route from the rear of the building was covered in algae which made the concrete slippery furthermore it was noticed that the bodies of dead birds were also fouling the walkway

Are persons at risk from means of escape deficiencies? Yes

Indicate the appropriate risk level: High

D: EMERGENCY ESCAPE LIGHTING

Description: Stand alone non-maintained units

- | | |
|---------------------------------------------------------------------------------|-----------|
| a. Maintained by | Not Known |
| b. Serviced to comply with the current British Standard 5266: | N/A |
| c. Tested to comply with the current British Standard 5266: | N/A |
| d. Date of last service: | N/A |
| e. Records up to date: | N/A |
| f. Is the emergency lighting system in good physical condition? | Yes |
| g. If no emergency lighting is provided or required indicate the justification. | /AN |

Comments and other relevant issues noted (list)

Note: see recommendations in the action plan/recommendations section of this report.

D, Emergency lighting required to be maintained over exit doors and escape routes. Lighting not extended to all areas and no records of tests or servicing seen at time of inspection

Are occupants at risk from emergency lighting deficiencies? Yes

Indicate the appropriate risk level: High

E: SIGNS AND NOTICES

Existing signs and notices provided comply with the Health and Safety (Safety Signs and Signals) Regulations 1996 and/or British Standard 5499 part 4-2000

Additional signs required?

Yes

If so please see the recommendations in section L, action plan.

Comments and other relevant issues noted (list)

Note: see recommendations in the action plan/recommendations section of this report.

E, See section 'E' in 'Fire Action Plan'

Are occupants at risk from signage deficiencies? Yes

Indicate the appropriate risk level: High

F: FIRE ALARM AND FIRE WARNING ARRANGEMENTS

Description of System: Manual with partial automatic detection.

- | | |
|-----------------------------------------------------------------------|-----------|
| a. Maintained by | Not Known |
| b. Does the system appear to conform to British Standard 5839 part 1? | Yes |
| c. Serviced to comply with British Standard 5839 part 1? | No |
| d. Tested to comply with British Standard 5839 part 1? | No |
| e. Date of last service? | Not Known |
| f. Records up to date? | No |
| g. Alarm connected to a remote monitoring centre? | No |
| h. History of false alarms? | No |

Comments and other relevant issues noted (list)

Note: see recommendations in the action plan/recommendations section of this report.

F, No records of tests or servicing seen at time of inspection

F, Fire detection system does not cover the entire premises

Are occupants at risk from fire alarm deficiencies? Yes

Indicate the appropriate risk level: High

G: FIXED AND PORTABLE FIRE EXTINGUISHING EQUIPMENT AND INSTALLATIONS.

G1; The following types of portable fire extinguishers are provided on site:
Carbon Dioxide Water

- | | |
|--------------------------------------------------------------------------------|-----|
| a. Are fire extinguishers adequate for the current risk? | Yes |
| b. Are fire extinguishers correctly sited and correctly identified by signage? | No |
| c. Are fire extinguishers adequately secured in position and not obstructed? | No |
| Extinguishers serviced by: unserviced | |
| d. Are fire extinguishers serviced in accordance with British Standard 5306? | No |
| e. Records up to date: | No |
| f. Date of last service? | N/A |

Comments and other relevant issues noted (list)

Note: see recommendations in the action plan/recommendations section of this report.

G1, Fire extinguisher not signed or secured to wall

G1, d, No records of tests or servicing seen at time of inspection

Are occupants at risk from fire extinguisher deficiencies? Yes

Indicate the appropriate risk level: High

H: MANAGEMENT OF FIRE SAFETY**H1; Fire Routine and Emergency Plan**

- a. Is there an established fire routine and emergency plan? No
- b. Are all necessary issues, included in the plan? No

Comments and other relevant issues noted (list)

Note: see recommendations in the action plan/recommendations section of this report.

H1, a & b, No codified fire routine and emergency plan in use at this time

H2; Training and Drills

- a. Are all staff given fire instruction on induction? No
- b. Are all staff given periodic refresher training at suitable intervals? No
- c. Have all staff been made aware of the emergency plan? No
- d. Are staff trained to recognise and use the fire extinguishers? No
- e. Are fire wardens appointed and trained? No
- f. Are there adequate numbers of fire wardens? No
- g. Are staff other than fire wardens designated to assist where necessary? No
- h. Evacuation drills held? No
- i. Date of last evacuation drill? N/A

Comments and other relevant issues noted (list)

H2, All section, No training or drills undertaken to date

H3; Record Keeping

- a. Is a dedicated fire log book maintained? No
- b. Are all appropriate records maintained? No

Comments and other relevant issues noted (list)

Note: see recommendations in the action plan/recommendations section of this report.

H3, a & b, No fire log book or records seen at time of inspection

H4; Disabled Persons and Visitors

- a. Are disabled persons employed? No
- b. Do disabled persons frequent premises? Yes
- c. Is management of disabled procedures satisfactory? No
- d. Is the procedure part of the fire routine, emergency plan and staff training? No
- e. Do visitors frequent the premises? Yes
- f. Is the managerial procedure for visitors satisfactory? No

Comments and other relevant issues noted (list)

Note: see recommendations in the action plan/recommendations section of this report.

H4, At the time of inspection no disabled persons were employed, however it is reasonable to expect that a disabled person may at some time in the future be employed or that a disabled person may have cause to visit the above establishment.No procedures for disabled staff or disabled visitors in place at this time

No formal procedure for disabled/able bodied staff/visitors in use at this time

Are any persons at risk from management deficiencies?Yes

Indicate the appropriate risk level: High

I: ACCESS FOR FIRE FIGHTING & FIRE FIGHTER SAFETY

- | | |
|----------------------------------------------------------------------------------------------------------------------------------|-----------|
| a. Is access for fire brigade vehicles satisfactory? | Yes |
| b. Is access for fire fighters on foot satisfactory? | Yes |
| c. Is access for fire fighting or means of escape clear and unobstructed? | Yes |
| d. Date of last Fire Brigade inspection, if known? | Not Known |
| e. Have the Fire & Rescue Service been advised of any changes to the building or occupancy? | Not known |
| f. Are local water supplies / hydrants adequate and suitably near to the building? | Yes |
| g. Are the local Fire Service made aware of any hazardous materials or issues, which might be hazardous when fire fighting? | N/A |
| h. Is external signage provided to warn fire fighters of storage hazards? | N/A |
| i. Are suitable fire-fighters switches provided? | N/A |
| j. Has the responsible person considered any issues, which might significantly damage or effect the environment in case of fire? | N/A |
| k. Has the possibility of fire spread to or from adjoining or adjacent buildings been considered by the responsible person? | N/A |

Comments and other relevant issues noted (list)

Note: see recommendations in the action plan/recommendations section of this report.

I, No comment required

Are occupants, the environment or fire fighters at risk from access or managerial deficiencies? No

Indicate the appropriate risk level: Normal

J: SCHEDULE OF RESPONSIBILITIES

The fire precautions listed below and the recommendations in this document, are required to be maintained by the responsible person at all times when the premises are occupied and should include contractors and cleaning staff employed to work in the premises.

Means Of Escape	Should be kept clear, available at all times when the premises are occupied and be kept free from ALL obstructions and combustible materials. They should be properly maintained and all fire doors onto means of escape should be kept closed when not in use.
Locks and Fastenings	All doors through which persons may have to pass to evacuate the building should only be fastened so that they can be easily and immediately be opened by one easy method without the use of a key.
Fire Alarm System	Where a workplace is equipped with fire detectors and alarms, they should be in operational order whilst the premises are occupied, and be maintained and tested to comply with the relevant code of practice.
Electrically Operated Doors	All doors fitted with electrically operated door release mechanisms should release open in the event of a power failure, or in the event of the fire alarm sounding. Where appropriate they should also be fitted with a break glass release point.
Portable Fire Fighting Equipment	A workplace should be provided with appropriate fire fighting equipment which should be kept available for use at all times, and be properly maintained to comply with the latest codes of practice.
Fire Signs and Notices	All fire signs and notices should be kept visible and in good order, and be fixed permanently.
Emergency Escape Lighting	Where installed, should be in good working order, be maintained and comply with the relevant codes of practice.
Training	All employees and contractors employed to work in the premises should be trained in the fire procedures. Up to date records of training should be maintained and employers should nominate employees (fire wardens) to assist in implementing the fire safety measures of the organisation.
Physically or Sensory disabled Persons	Procedures for physically or sensory impaired persons should be in place and special arrangements made as appropriate.
Steps, Stairs and Corridor Surfaces	Should be maintained in good order with non slip surfaces so they will not be a hazard to persons escaping in case of fire.
Furniture and Equipment	Should not be placed so as to cause an obstruction to persons, and should be placed so as to afford free passage to persons in case of fire
Fire Hazards	All combustible items of storage should be kept in such a way that they do not represent a fire hazard. Any flammable material should be kept to a minimum, and should be stored safely so as not be exposed to risk of ignition.
Fire Precautions Records and Fire Emergency Plan	All Fire related records and Fire Emergency Plans/procedures should be kept up to date and be available for inspection by any authorised person. The Fire Emergency Plan should be in a written format.

K: ASSESSING THE INDIVIDUAL RISKS

In order to assign priority to the risks identified, assessors must determine how likely the threat posed by each hazard is to happen. The simplest method of carrying out this prioritisation exercise is through the use of the matrix below.

In this matrix, assessors need firstly to determine how serious the hazard is (is it life threatening or merely an annoyance). This allows the assessor to place the hazard on the severity scale of the matrix (Low – Very High), running an imaginary line vertically from this placement gives one series of reference points.

Assessors now need to determine the probability of the threat actually happening (is it likely to happen almost daily, or is it unlikely to ever happen). Once this probability has been determined an imaginary line can be horizontally run from the identified probability on the left of the matrix to where it meets the imaginary vertical line already run from the severity scale. Where the two lines cross gives the resultant prioritisation for action to be taken (see key).

Likelihood	Very Likely <i>Could occur on a daily basis, or at least more than once per week</i>				
	Likely <i>Could occur more than once a month.</i>				
	Unlikely <i>Could occur within a year</i>				
	Remote <i>Only likely to occur once in a lifetime</i>				
		Low <i>negligible or light smoke inhalation only</i>	Medium <i>light to heavy smoke inhalation</i>	High <i>heavy smoke inhalation & risk of burns</i>	Very High <i>risk of serious injury or death</i>
		Severity			

KEY		Immediate action
		Action completed within 1 month
		Action completed within 3 months
		Action completed within 6 months

L: ACTION PLAN

The action plan which follows, sets out the risks to be eliminated or minimised to an acceptable level.

The action plan identifies the risk by cross reference to the various section where the deficiency has been identified (e.g. B. 1.a. portable appliance testing)

It provides details of the identified risk, the recommended action required to eliminate or minimise the risk and the priority given to the risk (e.g. action should be completed within one month)

Saction	Action	Priority Recommended time frame	Date Completed (Client Action)
B1	It is recommended that consideration is given to the electrical safety testing (PAT) of all electrically powered appliances and associated equipment, premises and other machines on an annual basis. General electrical circuits should be tested and checked by a competent contractor every five years.	One Month	
B3	Air conditioning plant/ electrically powered heaters, should be subject to periodic servicing by a suitably registered person in accordance with the manufacturers recommendations. Records of this work should be maintained in the fire log book.	One Month	
B7	<p>If the cover of soft furniture is damaged, the fire retardant qualities of that item cannot be guaranteed. Responsible person should check all soft furniture for damage weekly, and arrange for any damaged item to be repaired or replaced. This check should be recorded in the Fire Safety Log Book.</p> <p>The use of flame -retardant upholstered furniture and soft furnishings will substantially reduce the fire risk. All furnishings should comply with 'The Furniture and Furnishings (Fire Safety) Regulations 1988, as amended.</p> <p>Wall and ceiling linings, drapes and other hanging textiles should be of a fire retardant material or be appropriately treated with fire retardant chemicals. Textile fabrics that are capable of meeting these standards include durably flame retardant treated cotton and 100% flame retardant polyester. 100% monocyclic is also suitable if available.</p> <p>The retention of the flame retardant properties of textiles is dependant on the use of the correct laundry procedure being followed. Careful note of all wash and care instructions should be followed. Advice should be sought from the supplier if no instructions are readily available.</p>	Immediate	

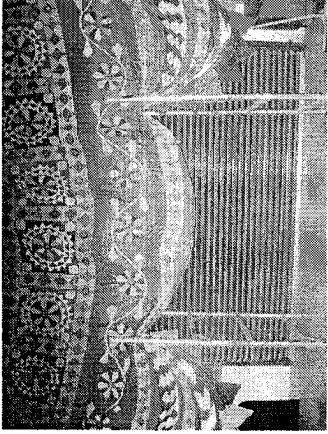
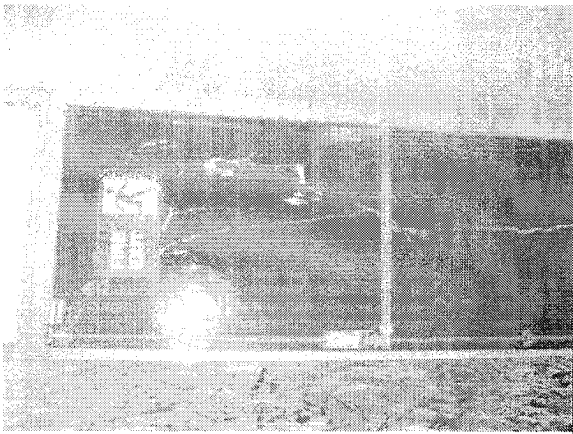
Section	Action	Priority Recommended time frame	Date Completed (Client/Action)
 <p data-bbox="517 1608 549 1816">Hanging fabrics</p>	<p data-bbox="587 752 655 1816">The under mentioned door was found to be damaged and difficult to open:- Rear exit door</p> <p data-bbox="692 786 794 1816">This door is required for means of escape and must be easily and immediately open-able from within, at all times that the premises are occupied in order to prevent persons being impeded/trapped in the event of fire.</p> 	<p data-bbox="587 544 619 689">Immediate</p>	

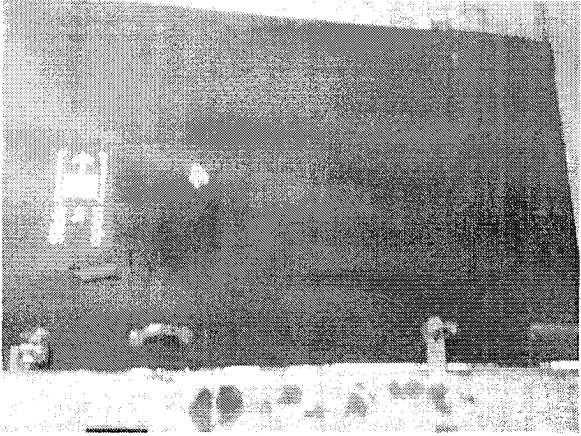
Section	Action	Priority Recommended time frame	Date Completed (Client/Action)
	<p>Rear exit door</p> <p>b & f, Sliding or revolving doors are not normally considered suitable for use on escape routes unless there are likely to be no more than five persons who may need to use them.</p> <p>The use of padlocks/chains etc is acceptable to secure doors when the premises are unoccupied. However, there must be a management system in place to remove them on occupation; this can be a numbered chain board in reception etc, for instant visual confirmation that the padlocks/chains etc, have been removed from the exits.</p>  <p>Sliding door rear exit</p>	<p>immediate</p>	
C2	<p>c, Items which pose a potential fire hazard or those which could cause an obstruction should not be located in or near areas which are intended for use as a means of escape in an emergency. In particular the following items should never be located in protected routes from the place of entertainment, or part of it: electrical equipments, such as photocopiers, portable heaters of any type.</p>	<p>Immediate</p>	

Subject	Action	Priority Recommended time frame	Date Completed (Client Action)
	<p>heaters which have unprotected naked flames or radiant bars, fixed heaters using a gas supply cylinder, where the cylinder is within the escape route,</p> <p>oil-fuelled heaters or boilers,</p> <p>cooking appliances,</p> <p>upholstered furniture,</p> <p>coat racks,</p> <p>temporarily stored items including items in transit, eg furniture, beds, bicycles, laundry,</p> <p>waste bins etc,</p> <p>lighting using naked flames,</p> <p>gas boilers, pipes, meters or other fittings (except those permitted in the standards supporting the building regulations and installed in accordance with the 'Gas Safety Regulations).</p> <p>Gaming and/or vending machines; Electrical equipment (other than normal lighting, emergency escape lighting, fire alarm systems, or equipment associated with a security system)</p> <p>e. The following fire doors should be upgraded or replaced, so that they comply with the definition 'fire resisting' as defined by British standard 476 :- Office doors. The doors to be provided with approved smoke seals and intumescent strips fitted to the top and both edges of the above mentioned fire door to prevent the passage of smoke and fire putting persons/premises at risk.</p> <p>Additionally any glazing within the doors to provide the required fire resistance. Any reference to fire resistance means a minimum of 30 minutes, in accordance with BS 476 unless otherwise stated.</p> <p>The electrical fuse board which is located within staircase enclosures and on an exit route, should be enclosed with fire resisting construction. The doors should be constructed of fire resisting material in order to provide a full thirty minutes fire resistance as defined by British standard 476. The door should be provided with a lock and the cupboard should be kept locked shut when not in use and bear a sign to that effect. Electrical intake cupboard doors required to be of fire resisting</p>	<p>One Month</p>	

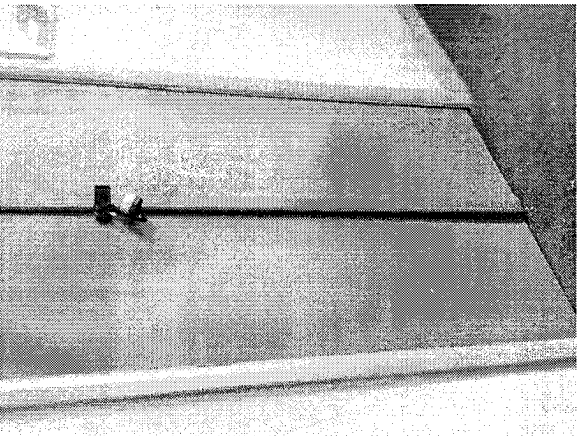
Reference	Description	Priority Responsible Time frame	Date Completed (Client Action)
	<p>construction are to be permanently marked on the outside, with a blue circular notice bearing the words KEEP LOCKED SHUT or FIRE DOOR KEEP LOCKED SHUT in white letters not less than 5 mm in height on the outer face of such doors.</p>  <p>Electrical intake cupboard doors</p>		
C3	<p>b & f. External escape routes that lead to a place of safety must be kept clear, free from obstructions and immediately available at all times. The external exit routes should be provided with an even, safe surface, which is without trip or slip hazards. Primary and secondary lighting should be provided over the entire external escape route</p>	Immediate	

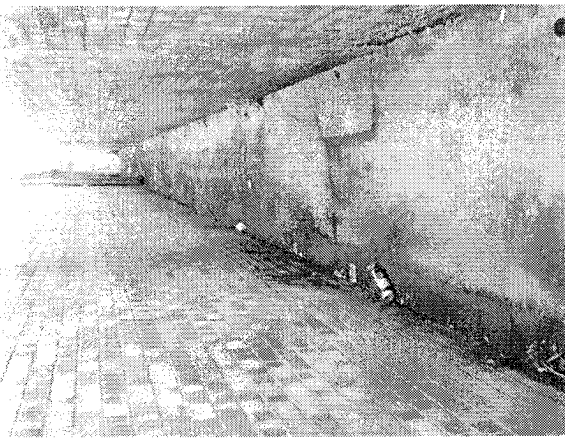
Section	Action	Priority Recommended time frame	Date Completed (Claim Action)
 <p>Side exit route</p>	<p>It is recommended that consideration is given to the provision of a servicing contract with a competent contractor who should maintain and test the emergency lighting system in accordance with the recommendations of British Standard 5266-8:2004 and be available to carry out repairs as necessary. All emergency light records should be kept within a dedicated fire log book</p> <p>It is recommended that a survey is made by an electrical engineer on all parts of the premises in order to ascertain how much light would be available in the event of a failure of the power supplies. Where it is apparent that the lack of lighting would endanger persons attempting to leave the premises in the event of a fire then consideration should be given to installing emergency lighting which will illuminate all appropriate areas to ensure that the system conforms to the requirements of British Standard 5266:1-2005. Final exit doors and external escape routes to be provided with maintained emergency lighting.</p>	<p>One Month</p> <p>One Month</p>	
<p>D</p>			

Section	Action	Priority Recommended time frame	Date Completed (Client/Action)
	<p><i>Maintained is generally used in places of assembly like theatres, cinemas, clubs and halls, the full list is contained within the BS 5266. These premises usually dim the lights during the time the premises are occupied and the emergency escape lighting prevents total darkness.</i></p>		
E	<p>Electrical intake cupboard doors required to be of fire resisting construction are to be permanently marked on the outside, with a blue circular notice bearing the words KEEP LOCKED SHUT or FIRE DOOR KEEP LOCKED SHUT in white letters not less than 5 mm in height on the outer face of such doors.</p> <p>Doors fitted with a panic latch or panic bolt fastening are to be indicated with the words PUSH BAR TO OPEN in block lettering at least 50 mm high. The lettering should normally be white on a green background and positioned immediately above the panic bar or on the operating bar if there is sufficient flat surface to accommodate the size of lettering.</p> <p>FIRE EXIT KEEP CLEAR signs should be placed on the outer surface of all doors that provide the final exit from a designated escape route.</p> <p>To make the presence of fire fighting equipment obvious, a notice bearing the words FIRE EXTINGUISHER, as appropriate, in white block lettering a minimum of 15 mm in height on a red background, should be provided.</p> <p>TO FIRE EXIT notices in bold white lettering on a green background should be positioned at each change of direction or part of the escape route where the exit door or doors are not readily visible to person using the escape route. The notices should incorporate a directional arrow facing towards the direction of escape and the 'running man' pictogram. Where necessary this should be suspended about head height.</p> <p>FIRE EXIT notices should be placed on the surfaces of all doors (direction of travel) that provide the final exit from a designated escape route or any doors, which act as and have any reciprocal bypass arrangement for any emergency egress. These signs should be in bold white lettering on a green background and include the 'running man' pictogram.</p>	One Month	

Section	Action	Priority Recommended time frame	Date Completed (Client Activity)
	<p>All fire resisting self closing doors are to be permanently marked on each side at eye level with a blue circular notice bearing the words FIRE DOOR KEEP SHUT in white letters not less than 5 mm in height.</p> <p>Printed FIRE ACTION notices should be displayed at conspicuous positions in the premises. They should state in concise terms the essentials of the action to be taken upon discovering a fire and on hearing the fire alarm. The notices should be permanently fixed in position and suitably protected to prevent loss or defacement, located in prominent positions, such as staff notice boards and fire alarm call points.</p> <p>All fire resisting self closing doors are to be permanently marked on each side at eye level with a blue circular notice bearing the words FIRE DOOR KEEP SHUT in white letters not less than 5 mm in height.</p> <p>In cases where the final exit door has no approved type locking device fitted or push bar, then the direction of door swing should be indicated, ie:- Push door to open or Pull to open</p> <p>No Smoking signs to be placed in a prominent position</p> <p>The above instructions should also appear in other languages most commonly used by staff.</p>		
F	<p>It is recommended that consideration be given to initiating a servicing contract with a competent contractor who should maintain and test the fire alarm system in accordance with British Standard 5839-1:2002. All servicing should be recorded in the fire log book</p> <p>It is strongly recommended that consideration is given to upgrading the existing fire alarm to a category L1 type fire alarm system, installed to the requirements of British Standard 5839:1-2002. Covering all areas of the premises</p>	One Month Three Months	
G1	<p>The fire extinguishers provided should be serviced and maintained in accordance with British Standard 5306:pt3 and a record of the results kept in a log book.</p>	Immediate	

Section	Action	Priority Recommended time frame	Date Completed (dd/mm/yyyy)
	<p>It is recommended that arrangements are made to have all fire extinguishers hung on brackets or placed within floor stands which are affixed to the walls and that recorded managerial checks are initiated which should ensure that the fire extinguishers provided are in position and available for use at all times and not obscured/ obstructed by storage or refuse.</p> <p>Fire extinguishers should normally be located in conspicuous positions on escape routes, preferably near exit doors form both the building and each storey. Wherever possible, fire-fighting equipment should be grouped to form fire points. These should be clearly visible or their location clearly and conspicuously indicated so that fire points can be clearly identified.</p> <p>It is considered best practice is to create "fire points" adjacent to each fire exit door comprising exit signage, fire alarm actuation point, emergency lighting (where required), fire action notice and fire fighting equipment. A suitable fire extinguisher must be made readily available near to any hot work being carried out for the fire safety protection of the operative</p>		
H1	<p>The fire action notices which are recommended in section E, will be considered a site sufficient emergency plan,</p>	Immediate	
H2	<p>All staff must be aware of any responsibilities they may have if the building needs to be evacuated and all staff must receive training in the fire emergency plan and escape routes available.</p> <p>This training should also be provided for persons on irregular duties or shift duties outside normal working hours, including part-time staff, cleaners etc.</p> <p>Instruction should be given by a competent person at such intervals as to ensure that everyone at work has received fire safety training, preferably at least twice in each period of twelve months. It is particularly important that management ensure that all newly appointed and temporary staff are made aware of the means of escape and fire procedures at the commencement of their employment.</p>	Three Months	

Section	Action	Priority Recommended time frame	Date Completed (Client Action)
	<p>Training should be based on written instructions but it is important that they are specific to these premises and the current occupier. Reliance upon a standard instruction of a type used by many large organisations may not be satisfactory without modification to suit your individual need.</p> <p>As a minimum, all staff should receive the following training,</p> <p>They should be told if they have any special duties when the fire alarm sounds.</p> <p>They should receive instruction about all the items listed in your emergency plan and the evacuation procedures.</p> <p>They should be given instruction in how to maintain a safe venue by keeping fire-resisting doors shut and keeping the escape routes clear of obstructions, sources of ignition and combustible storage.</p> <p>They should be told of the importance of keeping the fire fighting equipment available.</p> <p>They should be shown how were required to safely shut down machinery before leaving the building.</p> <p>Fire warden and specialist training</p> <p>A Fire Warden should be appointed to take charge of the evacuation when the fire alarm sounds, the Fire Wardens should ensure that everyone leaves the building and they should check the toilets and other enclosed spaces where people may be.</p> <p>On arrival at their assembly point, they should conduct a roll call and then report to the Fire Safety Officer or senior person present. The location of the fire or cause of the alarm should be reported to the officer in charge of the first fire appliance to attend if this information is known.</p> <p>The Fire Wardens should receive training to use the fire extinguishers provided. If a small fire is discovered they should fight the fire with the extinguishers provided</p>		

Section	Action	Priority Recommended time frame	Date Completed (Client Action)
	<p>if they consider they can do so without taking personal risks. The Fire Wardens should also receive instruction on maintaining the fire precautions and report any defects to the responsible person.</p> <p>It is recommended that the safe management of any disabled person or visitor to the premises is considered and included in the training which fire wardens receive.</p> <p>In order to assist young, infirm, disabled or sensory impaired people to escape from fire it may be necessary for staff to be trained in the correct procedures to cope with this eventuality. The need to provide direction and guidance for persons who are unfamiliar with the premises, e.g. visitors etc, should be taken into account. Outside contractors, where appropriate, should also be considered when formulating training needs.</p> <p>Fire evacuation drills</p> <p>A practice fire drill should be carried out at least once and preferably twice each year simulating conditions in which, where appropriate, one of the escape routes from the building is considered to be unavailable. During these drills the fire alarm should be operated or the alarm of fire raised verbally by a member of staff who is told of a supposed outbreak of fire, and thereafter the fire routine should be rehearsed as fully as circumstances allow.</p> <p>Training records</p> <p>All training and instruction should be recorded in a log book. The following are examples of matters which may need to be included in such a record:- See section 'H3 Record Keeping' in the fire action plan!</p> <p>The date of the instruction or exercise. The duration and the name of the person giving the instruction or drill. The names of the persons receiving the instruction or taking part in the drill. The nature of the instruction or drill.</p> <p>Fire fighting equipment</p>		

Section	Action	Priority Recommended time frame	Date Completed (Item Action)
H3	<p>It is recommended that employees are trained in the use of the fire extinguishers provided. It should be remembered that persons attempting to use the extinguishers, without training, may be at risk from a fire through inappropriate use and a lack of fire fighting awareness. Article 13 of The Regulatory Reform (Fire Safety) Order imposes a duty on employers to provide adequate training for any persons who may be expected to use the equipment that they have provided.</p> <p>It is recommended that a dedicated fire log book is provided, in which all fire related records should be maintained.</p> <p>The log book records remind management to complete regular training, tests and checks. Failure to carry out the tests etc could result in increased risk due to failure of the fire precautionary arrangements in an emergency.</p> <p>Maintain comprehensive records in the fire log book provided of all:-</p> <ul style="list-style-type: none"> fire alarm actuations, servicing and tests, emergency light tests, servicing and checks, staff fire training, fire evacuation drills, fire extinguisher checks and tests, means of escape checks, portable electrical appliance tests, checks of any portable lamps or torches. 	Three Months	
H4	<p>No detailed procedure or policy was found on site, which deals with all aspects of access and egress, for disabled staff/visitors in the event of an emergency</p>	Three Months	

Section	Action	Priority Recommended time frame	Date Completed (Calend / Action)
	<p>Any disabled person in the premises could be at risk unless suitable disability procedures are devised, which take all issues and staff into account and are understood by all appropriate staff members.</p> <p>It is recommended that the safe management of any disabled persons in the premises is actively considered and included in the fire emergency plan and training. In practice this may include the need to enquire with staff and visitors as to any special needs they may have in the event of an emergency and then require the provision of adequate and appropriate arrangements as a result.</p> <p>Disability can occur in many forms and staff and fire wardens should be vigilant in order to identify persons who may need assistance in some way. Planning for these eventualities should take place prior to an emergency so that arrangements can be put in place immediately they are needed.</p> <p>The difficulties of people with a wide range of physical or mental disabilities must be taken account of.</p> <p>Therefore, in order to meet the requirements of the Disability Discrimination act, consideration may be necessary for the provision of visual or physical signals to augment the audible fire alarm warning as appropriate and additional physical measures may be necessary.</p> <p>Under the disability discrimination act, if disabled people could realistically expect to use the service, which you provide, then you must anticipate any reasonable adjustments that could make it easier for that right to be exercised. Accordingly if disabled people are going to be in your premises, then you must also provide safe means for them to leave if a fire occurs.</p> <p>Where disabled employees (it is appreciated that you do not have any employees with disabilities at this present time, however that may change at any time) and other disabled people frequently use your premises you may need to develop an individual 'personal emergency evacuation plan' (PEEP)</p>		

Section	Action	Priority Recommended time frame	Date Completed (Date, Action)
	<p>VISITORS</p> <p>It is recommended that the safe management of visitors to the premises is considered and included in the fire emergency plan and training. As a general rule it might be considered appropriate that the host member of staff is made responsible for the safety of visitors in case of fire and that a visitors book is maintained which would be used to aid roll call after a fire evacuation had taken place.</p>		

N: OCCUPANCY FIGURES

100-108 Markfield Road **Occupancy figures**

Introduction

Mr Abhi Beltharia requested HASAW to conduct a survey of the above premises to ascertain the correct occupancy figures to apply to the building. Mr Beltharia has been provisionally given an occupancy figure of 450 persons.

The premises consist of a single storey brick built, mid to late XX century light industrial unit construction. With three exits, one situated at the front of the building and two at the rear. Furthermore, a roller shutter 3 metres wide is also featured at the front of the premises, which is at this time not included in the local authority calculation as a designated means of escape.

At the time of inspection the building was not in use or furnished and the internal layout has not been finalised.

The premises are at time of writing awaiting a fire risk assessment which should be read in conjunction with this report.

The intended use of the premises appears to be for the purposes of public entertainment and the occupancy figures have been based on that usage.

Occupancy Figures - general principles

The occupant capacity is an essential factor in assessing means of escape.

To calculate the occupancy factor the following needs to be taken into consideration:

The calculations set out below are relevant to premises of a good general standard of construction, with sound foundations supporting walls of block, brick, stone, or modern insulated treated wood construction, supporting a substantial roof of traditional construction. The internal walls, floors and ceilings are to be sound, and covered by non combustible surface coverings, doors should be substantial and well fitting. The services and equipment should be to the required certificated standards, being tested and maintained.

Should the premises not be to these standards, it may be necessary to assess that a fire could spread through the premises more quickly. Therefore, the time given for the evacuation of persons could be reduced. A reduction in the time to evacuate a premises or room will affect the overall occupancy limit provided.

With this in mind a premises with a less than an adequate standard of construction, could have occupancies restricted by as much as 20% from the calculations provided below.

1. *Confirm what the specific room/area within the building is used for i.e. dancing, seating, standing, etc. In areas where fixed seating is provided, the major part of the occupancy capacity will be determined by the number of seats available. In areas without fixed seating the capacity will be calculated by the available floor areas. If the maximum use is to be made of the building, the available exits should be sufficient in number and width to permit safe evacuation of the calculated occupancy of persons within the building.*
2. *The calculated occupant capacity of a premises or part thereof should be determined by:*
 - a) *In areas where fixed seating is provided:*
 - i. *If individual seats, by the number of such seats.*
 - ii. *If bench seats, or similar continuous seating, by dividing the total width of such seating by 450mm. i.e a 4.5 metre length of fixed seating = 4.5m = 4500mm divide by 450 mm = 10. Therefore 10 persons could be permitted to sit at the fixed seating area.*
 - b) *In other areas (including standing areas occupied together with fixed seating) divide the floor area into metres² by the relevant occupancy load factor.*

Note: Toilets, bar serving areas, DJ booths, stores, fixed furniture and similar areas are to be excluded.

Occupancy Table Load Factors	
Use of Room or Floor	Occupant Load Factor (m ² per person)
Assembly Dance Hall, Venue for Pop Concert and like occasion, Queuing Area	0.5 *
Bar	0.3 to 0.5

3. Exit capacity.

Although the calculated number of persons can be accommodated in a specific room or premises, there has to be provision to get these people from the room in the event of emergency. Therefore, there has to be a sufficient number of exit doors available, each of adequate width, to allow all persons in the room/premises to evacuate as quickly as possible.

Each door width should be a minimum of 750mm (900mm for disabled exit and access).

To measure the usable width of an opening, i.e. when the door is fully open, the measurement must take into consideration any projections into the doorway or elsewhere around the exit route from the opening in the room.

*The number of persons who could be expected to exit through a 750mm opening within a specified time would be 60 persons. Therefore, a guide for larger rooms would be:
1050mm opening - 220 persons*

For door width larger than 1050mm an extra person can be added to every 5mm added to the door width. No individual exit door leaf should be greater than 2m in width.

Maximum total in premises at any one time.

The approximate area of the premises is 643m². Situated in one corner of the building is an office and in another corner toilet facilities, which occupies about 83m² leaving approximately 560m² of the public area available. Using the above figure of 0.5m² per person the occupancy figure before means of escape is considered is **1120 persons**

The escape routes available need to be calculated to ensure that there are sufficient exits from each part of the building for persons to escape safely.

Means of escape figures

The current exits available are two exit doors at the rear of the building which due to their location and proximity should be counted as one exit. The widths of each is 750mm and 1220mm respectively, the latter at this time is fitted with a sliding door (see risk assessment for further guidance) and one exit at the front of the building of 1700mm. (a further exit has been proposed to be formed where the roller shutter is now).

Exit A (tea area rear door) 750mm = 60 persons

Exit B (rear sliding door) 1220mm = 220 + (*For door width larger than 1050mm an extra person can be added to every 5mm added to the door width*) 34 = 254

Exit C (front entrance door) 1700mm = 220 + (*For door width larger than 1050mm an extra person can be added to every 5mm added to the door width*) 130 = 350

On this basis the exits A & B (due to their close proximity) have a combined or aggregated total of (60+254) 314 persons.

Exit C has 350 persons.

Discounting the largest exit which may be put out of action due to fire i.e., exit C (350 Persons) the proposed maximum occupancy figure incorporating the current door configuration is **314 Persons**.

Proposal to increase the current occupancy figures

In order to obtain a theoretical occupancy of approximately 1000 person the following proposals may be considered:

Taking into account the existing double exit doors at the front of the building, which allow for 350 persons to leave the building safely, it is recommended that a further two sets of exit doors of 1500mm each are formed within the existing space occupied by the roller shutters.

Furthermore, at the rear of the building three additional exit doors to be formed, each of approximately 1500mm (the existing sliding opening may be incorporated within the proposed new rear doors). It should be noted openings equivalent to the rear exit doors should be provided within the curtain wall that is located toward the rear of the building.

The proposed exits would provide a revised occupancy as follows:

Rear escapes

1 X 1500mm doors = 220 persons + a further 90 persons = 310 persons

2 X 1500mm doors = 440 persons + a further 180 persons = 620 persons

3 X 1500mm doors = 660 persons + a further 270 persons = 930 persons.

Front escapes

Existing door of 1700mm = 220 persons + 130 persons = 350

2 X 1500mm doors = 440 persons + a further 180 persons = 620 persons

Providing a total of **970 persons**.

The new doors at the front and rear of the building are each to be considered as one escape route allowing total evacuation from either the front or the rear of the building.

As we cannot tell where the fire will start, the largest exit is always discounted in case the fire stops people using it. So discount the largest exit and this is the maximum exit capacity, which in this case will remove either the front escape routes or the rear escape routes in their entirety.

Taking into account the above guidance, the proposed front exit routes will provide escape for 970 persons and the rear escape routes for 930 persons.

The final proposed theoretical occupancy should not exceed **930* persons**.

M: PREMISES RISK CATEGORISATION

Generally, workplaces can be categorised as either High Normal or Low Risk

High = Where highly flammable or explosive materials are stored or used (other than in small quantities).

Where unsatisfactory structural features are present such as :-

- a) a lack of fire resisting separation;
- b) vertical or horizontal openings through which fire, heat and smoke could spread;
- c) long and complex escape routes created by extensive subdivision of large floor areas by partitions, or the distribution of display units in shops or machinery in factories;
- d) large areas of flammable/combustible or smoke producing surfaces on walls or ceilings.

Where permanent or temporary work activities are carried out which have the potential for fire to start and spread such as :-

- e) workshops in which highly flammable materials are used, eg paint spraying;
- f) areas where the processes involve the use of naked flame, or produce excessive heat;
- g) large kitchens in works canteens or restaurants;
- h) refuse chambers or waste disposal areas;
- i) areas where foamed plastics or upholstered furniture are stored.

Where there is a significant risk to life in case of fire, such as where :-

- j) sleeping accommodation is provided for staff, the public or other visitors in significant numbers;
- k) treatment or care is provided where the occupants have to rely upon the actions of limited numbers of staff for their safe evacuation;
- l) there is a high proportion of elderly or infirm people, or people with temporary or permanent physical or mental disabilities, who need assistance to escape;
- m) groups of people are working in isolated parts of the premises such as basements, roof spaces, cable ducts and service tunnels etc;
- n) large numbers of people are present relative to the size of the premises (e.g. sales at department stores) or in other circumstances where only a low level of assistance may be available in an emergency (e.g. places of entertainment).

Normal = Where any outbreak of fire is likely to remain confined or only spread slowly, allowing people to escape to a place of safety.

Where the number of people present is small and the layout of the workplace means they are likely to be able to escape to a place of safety without assistance.

Where the workplace has an effective automatic warning system, or an effective automatic fire-extinguishing, suppression or containment system, which may reduce the risk classification from high risk.

Low = Where there is minimal risk to peoples lives and where the risk of fire occurring is low, or the potential for fire, heat and smoke spread is negligible.

FIRE DETECTION AND ALARM SYSTEM COMMISSIONING CERTIFICATE

Certificate Reference:

DETAILS OF THE CLIENT

Client: **MARKFIELD ART LTD**
 Address: **SUITE 17789 LOWER GROUND FLOOR**
145-157 ST JOHN STREET
ECL 4PW

DETAILS OF THE FIRE DETECTION AND ALARM SYSTEM

Installation Address: 100-108 MARKFIELD ROAD LONDON N15 4QF	The Installation is: New An alteration An addition <input checked="" type="checkbox"/>
Extent of system covered by this certificate: ALL NEW SOUNDERS, CALL POINT AND BEACONS	

SYSTEM EXAMINATION AND RECOMMENDATIONS

<ul style="list-style-type: none"> <input checked="" type="checkbox"/> All equipment operates correctly <input checked="" type="checkbox"/> Installation work is, as far as can reasonably be ascertained, of an acceptable standard <input checked="" type="checkbox"/> The entire system has been inspected and tested in accordance with the recommendations of Clause 39.2c) of BS 5839-1:2002 The system performs as required by the specification prepared by: N/A a copy of which I/we have been given	The following work should be completed before/after (delete as applicable) the system becomes operational: None The following potential causes of false alarms should be considered at the time of the next service visit: None Before the system becomes operational, it should be soak tested in accordance with the recommendations of Clause 35.2.6 of BS 5839-1:2002 for a period of: N/A weeks (Enter a period of either one week, such period as required by the specification, or such period as recommended by the signatory to this certificate, whichever is the greatest, or insert N/A if not applicable.)
---------------------------------------------------------------------------------------------------------------------------------------------------------------------------------------------------------------------------------------------------------------------------------------------------------------------------------------------------------------------------------------------------------------------------------------------------------------------------------------------------------------------------------------------------	-------------------------------------------------------------------------------------------------------------------------------------------------------------------------------------------------------------------------------------------------------------------------------------------------------------------------------------------------------------------------------------------------------------------------------------------------------------------------------------------------------------------------------------------------------------------------------------------------------------------------------------------

CERTIFICATE OF COMMISSIONING

I/We being the competent person(s) responsible (as indicated by my/our signatures below) for the commissioning of the fire alarm system, particulars of which are set out above CERTIFY the the said work for which I/we have been responsible complies to the best of my/our knowledge and belief with the recommendations of Clause 39 of BS5839-1:2002, except for the variations, if any, stated in this certificate.

Variations from the recommendations of Clause 39 of BS 5839-1:2002 (see BS 5839-1:2002, Clause 7).

None

The extent of liability of the signatory/signatories is limited to the work described above.
 For the **COMMISSIONING** of the system:

Name: **J. NELSON** Position: **FIRE ALARM ENGINEER** Signature: Date: **26/9/12**

DETAILS OF THE ELECTRICAL CONTRACTOR

Trading Title:
 Address:
 Registration Number:
 Telephone Number:
 Postcode:

RELATED REFERENCE DOCUMENTS

Design Specification Ref No:	N/A	Date issued:	N/A	Electrical Installation Certificate No:	N/A	Date issued:	N/A
Design Drawings Ref No(s):	N/A	Date issued:	N/A	Fire Alarm Design Certificate No:	N/A	Date issued:	N/A
'As Fitted' Drawing No(s):	N/A	Date issued:	N/A	Fire Alarm Installation Certificate No:	N/A	Date issued:	N/A

APPENDIX 1C – OPERATION MANUAL

Markfield Arts

OPERATION MANUAL FOR EVENTS AND EXHIBITIONS

ADDRESS

100-108

MARKFIELD ROAD

LONDON

N15 4QF

MARKFIELD ARTS

Co.no. 07916106 Regd office: suite 17789,lower Ground floor 145-157 st. John street EC1V4PW

--	--

MARKFIELD ARTS

Co.no. 07916106 Regd office: suite 17789, lower Ground floor 145-157 st. John street EC1V4PW

1.0 Who's who and contact details	
1.1 intentions	
1.2 objectives	
1.3 background	
1.4 outline of events to be held at the premises	
1.5 operating schedules i stage operation schedule ii bar operations iii proof of age scheme	
1.6 provision of late night refreshment	
1.7 entertainment	
2.0 prevention of crime and disorder. The prevention of nuisance	
2.1 definitions and demographic	
2.2 security	
2.3 glass free environment	
2.4 drugs, misuse and supply	
2.5 weapons and drugs searches	
2.6 stewarding	
3.0 public safety	
3.1 Premises site suitability	
3.2 access and exits i build phase access ii show time access iii emergency vehicle access iiii visitor log	
3.3 arrival of patrons	
3.4 traffic management plan	
3.5 pedestrian emergency exits	
3.7 food hygiene standards and catering	
3.8 drinking water	
3.9 waste management	
4.1 sound management	
4.2 sound monitoring	
4.3 internal communication	
4.4 complaints procedure	
5.0 the protection of children from harm	
5.1 admissions policy	
5.3 refusal of entry	
6.0 emergency procedures and roles	
6.1 the role of the police	
6.2 the role of the ambulance service	
6.3 the role of the fire brigade	

MARKFIELD ARTS

Co.no. 07916106 Regd office: suite 17789,lower Ground floor 145-157 st. John street EC1V4PW

6.4 emergency management procedures	
6.5 emergency response plan	
6.6 fire precautions and equipment	
6.7 medical cover and first aid provision	
6.8 event control	
6.9 insurance	
7.0 competent contractors and crew	
7.1 electrical supplies and installations	
7.2 lighting	
7.3 pat	
8.0 sanitary provision	
9.0 temporary installations and structures	
10.0 signage	
11.0 Load in and load out	
12.0 decoration/structures	
13.0 market area and traders	
14.0 documentation and reporting	
15.0 site safety rules	
16.0 Accreditation	
17.0 CCTV	

Appendix A	Risk assessments
Appendix B	Fire Risk assessments
Appendix C	licences
Appendix D	Security and Stewards
Appendix E	Signage
Appendix F	web site
Appendix G	Caterers & Traders
Appendix H	Sound Management
Appendix I	Sanitary Provision
Appendix J	Insurance
Appendix K	Medical
Appendix L	Terms and conditions
Appendix M	Tents and structures
Appendix N	Show Lighting
Appendix O	Electrical supply
Appendix P	Site and area plans
Appendix Q	Waste Management
Appendix R	Accreditation

MARKFIELD ARTS

Co.no. 07916106 Regd office: suite 17789,lower Ground floor 145-157 st. John street EC1V4PW

1.0 WHO'S WHO AND CONTACT DETAILS

NAME	ROLE	CONTACT NUMBERS
Abhishek Beltharia Markfield Arts Ltd	Building Manger Premises License holder DPS	07896993830
	Private hire coordinators Promoters Producers	
Duty site manager		
Paul Martin-Bacon	Site manager Deputy DPS	0771 0088 947
James Dagless	Site manager Sound management	07793 079534
J.Boothe NSC Noble Security Consultants Ltd	Security SIA .Stewards.	07882 660195
Police licencing Officer Police duty officer		
Haringey council Environmental Health Officer		
Haringey Fire brigade Duty officer		
Darren Johnson-Rose Uk Survey Ltd	CAD Design and building Surveying Services	07814 452536 01543 222915
Terry Telles J& L	Planning and development	

planning services	consultancy	01322 281444
Ambulance service		

1.1 INTENTIONS

Markfield Arts Ltd's business model is to hire 100-108 Markfield Road and the logistical support of the premises management team to our professional clientele; it is not intended to run as a regular nightclub or discotheque.

As all operations are extremely varied and on a contractual hire basis Markfield arts have applied for comprehensive licensable activities to accommodate this business model

The intentions are

- To plan and promote a safe and well-managed premise to facilitate our clients needs
- To provide adequate provision for disabled patrons.
- To plan and promote an environment that minimises the risk of crime and disorder.
- To prevent public nuisance.
- To protect children from harm.
- To minimise any impact on the surrounding environment arising from our activities.

There will be a robust application process to assist license holder to ensure these intentions are met

1.2 OBJECTIVES

To help achieve these intentions the operations manual will:

- Clearly define the parameters of the premises
- Identify roles, responsibilities and duties.
- Identify communication lines.
- Identify safety measures and their implementation.

In planning any activity at the premises, notice has been taken of successful measures from past licenced activities by the managers, and guidance from regulatory bodies. Particular regard has been taken of:

HSE guidance:

- The Event Safety Guide.
- Managing crowds safely.
- Fire safety risk assessments open air events and venues

BS 9999

Legal requirements

The Licensing act 2003

Health and safety at work act 1974

The management of health and safety at work Regulations 1999

Health and safety signs and signals regulations 1996

Control of substances hazardous to health regulations 1999

1.3 BACKGROUND

Previous events:

The management team have been involved in numerous events ranging from music events theatre and film productions, exhibitions and to date 5 fully licenced festivals

Offworld Festival 2007/2008

Shattered Barriers electronic music and art installation events from 2010

Cosmo Festival 2010/2011/ 2012

Conspiracy for good: Role play multi-media game in central London (Emmy Nominated)

Art exhibition management and touring logistics for private collections

Set design and stage management at the national theatre

Tour management and production for 1157 theatre group

The Royal British legion 90th anniversary celebrations 2011

1.4 OUT LINE OF EVENTS AND EXHIBITIONS TO BE HELD AT THE PREMISES

The aim is for the space to be versatile and flexible to accommodate a diverse and wide range of client's needs

Exhibitions

Film and photo shoots

MARKFIELD ARTS

Co.no. 07916106 Regd office: suite 17789,lower Ground floor 145-157 st. John street EC1V4PW

Private event hire

Recorded and live music events

Music and theatre production

Workshops in dance, arts and cultures

Conference and Seminars

Licensed Bar & Cafe

Activities at the premises will be contained within the site perimeter and will accommodate all patrons, crew, performers and crew vehicles. To aid the management and security

The venue is not normally open to the general public. It is well maintained, and is free of trip/slip hazards in the areas that will be used.

Any elements being introduced to the site will be done so with due Consideration, ensuring hazards are kept to a minimum.

Provisions can made to accommodate a maximum 930 on site
All plans and calculations will be based on the expected capacities of each event
Insurance arrangements will in line with these numbers.
Audience numbers will be monitored in the days leading up any event through a ticket system or correlation of guest/participants lists

1.5 OPERATING SCHEDULES

Operating schedules and contact sheets will be created for each event at the premises from load in to load out

BAR OPERATIONS

The Premises Licence Summary will be prominently displayed at the bars.

There will be challenge 21 posters on plain view at the bars.

There will be a PASS card recognition guide in plain view of the staff.

There will be a refusal policy and a log maintained at each bar.

Designated premises supervisor (DPS) and Personal licence holders

Mr Abhishek Beltharia is to be the DPS Personal Licence no 12/00099/lipers

Mr Paul Marin Bacon is to be deputy DPS Personal license no PA106912

See Appendix C, licences, Bar Operations and Certificates

MARKFIELD ARTS

Co.no. 07916106 Regd office: suite 17789, lower Ground floor 145-157 st. John street EC1V4PW

Professional bar staff shall be employed to work under the direction of a bar manager.

All bar staff are to be over twenty one years of age and have the relevant experience and authorisation.

Bar staff will be briefed in;

- Emergency procedures
- Site safety rules
- Employees duties under the 1974 Health and safety at work act
- Manual handling
- Proof of age policy
- Drunk or intoxicated policy
- Aggressive or anti-social behaviour policy
- Opening and closing times
- Complaints procedure
- Hygiene standards and procedures
- Challenge 21 and PASS recognition

PROOF OF AGE SCHEME

The organisers will promote on all media employed the Challenge 21 scheme. Any person who bar staff believes may be less than 21 years of age must produce proof of age, identification. If that individual cannot produce proof of age such as recognised photo identification, that individual will not be served alcohol.

1.6 PROVISION OF LATE NIGHT REFRESHMENT

A café space is planned for the provision of late night refreshment

1.7 ENTERTAINMENT

Provision will be made in areas to allow patrons to dance to live and recorded music

Provision shall be made for a café

There will be licensed bars operated under the control of Mr Abhishek Beltharia DPS and personal license holder.

Provision shall be made for performance of dance, juggling and theatrical performances

- There are no plans or provisions for entertainments that are of an adult or sexual nature.
- There are no plans or provisions for wrestling/boxing or gambling of any kind

2.0 THE PREVENTION OF CRIME AND DISORDER & PREVENTION OF NUISANCE

Measures will be adopted to ensure any activity at the premises is well organised and policed internally & externally by qualified professional security. All measures

MARKFIELD ARTS

Co.no. 07916106 Regd office: suite 17789,lower Ground floor 145-157 st. John street EC1V4PW

are based on intelligence from previous successful events. The organisers fully intend to develop their plans in consultation with the Police & Council.

Prevention of nuisance from noise/ vibration

All windows will remain closed during the licensed regulated entertainment activities or in any event after 11pm. The entrance door will be fitted with a self-closing device and staff required to ensure that it is not propped open. A member of staff shall be made responsible to ensure the door is opened for as brief a period as possible. Where necessary adequate and suitable mechanical ventilation should be provided to public areas.

Entry to the premises will be restricted to the main entrance as indicated on the site plan whilst the premises is being used for regulated entertainment & licensed activity

Entrance/exit from the premises whilst regulated entertainment & licensable activities ongoing shall be via a lobbed door to minimize noise breakout.

The regulated entertainment & licensable activity shall conclude 30 minutes before the premises is due to close to prevent excessive noise breakout as the premises empties.

Sound Limits

The licensee shall ensure that no music played in the licensed premises is audible at or within the site boundary of any residential property.

Outside Areas.

No music will be played in, or for the benefit of patrons in external areas of the premises

No form of loudspeaker or sound amplification equipment is to be sited on or near the exterior premises, in or near any foyer, doorway, window or opening to the premises

The number of person permitted to utilize the external area/frontage will be restricted

Plant & Machinery

All plant and Machinery is correctly maintained and regularly serviced to ensure that all activities is operated efficiently and with minimal disturbance to neighbours arising from noise

Dealing with complaints

A complaints book will be held on the premises to record details of any complaints received from neighbours. The information is to include the complaint's name, location, date time and subsequent remedial action undertaken. This record must be made available at all times for inspection by council officer

Patrons entering/exiting premises

Where people queue to enter the premises a licensed door supervisor has to supervise and ensure the potential patrons behave in an acceptable answer.

MARKFIELD ARTS

Co.no. 07916106 Regd office: suite 17789,lower Ground floor 145-157 st. John street EC1V4PW

Signs should be displayed requesting patrons to respect the neighbour and behave in courteous manner.

Door Supervisors

Door supervisors to be on duty at all times during regulated entertainment and when licensed alcohol sales are ongoing.

When the premises turn out, a licensed door supervisor shall supervise patron and ensure they leave in a prompt and courteous manner, respecting the neighbours.

A suitable number of licensed door supervisors will be available to ensure that any people gathering outside the premises will be encouraged to disperse or to enter the premises. Any persons attempting to enter the premises with alcohol will not be allowed into the premises. Any such alcohol will be confiscated and disposed

Any person wishing to consume their own alcohol before entry should be allowed to do so within the forecourt of the premises behind the premises fence and out of sight of the street.

A licensed door supervisor will be positioned on the exit door to ensure, as far as Reasonably practical, that patron does not leave with drinks.

A licensed door supervisor will patrol the curtilage of the premises to prevent patrons urinating in public in the vicinity of the premises

Prevention of nuisance from litter

Adequate receptacles for use by patrons will be provided in the local vicinity. The positioning of the receptacles will agree with the licensing officer.

2.1 DEFINITIONS AND DEMOGRAPHIC

Definition of The Premises for hire

The premises will encapsulate all the licensable activities applied for

The premises is strictly on a hired to clients basis and will be designed as a multi-purpose multi- functional space to accommodate our clients specific needs and plans

Operations will be flexible to accommodate the client's logistic needs, which are expected to change on a hire-to-hire basis.

Definition The premises management team

The Premises management teams function is to support our client's to achieve their creative & business objectives and to oversee safety procedures and protocols and ensuring that licensable conditions are met throughout each contractual period.

Definition of the Client

Any person, company or body who hires the premises to operate within the licence conditions and contractual conditions of Markfield Arts

Demographic

The demographic of the client and the client's guests will be defined in the application process

Adequate SIA personnel, support personnel and amenities will be employed based on this information

All calculations will be in line with HSE guidance

2.2 SECURITY

See appendix D Security and Stewards

Security will be engaged to provide security cover.

The duties of security will include

- Patrolling the premises
- Patrolling the production areas
- Assisting the management team in maintaining a safe environment

Security Profile

- All staff are SIA trained certificated and registered with visible I.D
- Provide cover during hours when open to public
- Supply NVQ stewards

Security/Stewarding Provision

- Security Numbers will set in line with HSE guidelines
- NVQ steward numbers will set within HSE guidelines

IDENTIFYING SECURITY

Security will have their SIA badges on display on their arm and will be in suitable clothing making them easily identifiable as security personnel.

Security personnel will be issued with radio communication equipment and allocated a dedicated channel.

2.3 GLASS FREE ENVIRONMENT

Drinking glasses, glass bottles or anything of a similar nature will not be permitted on site and if found shall be disposed off by the management.

2.4 DRUGS POLICY

Communications outlining our Drugs Policy will be made available to all participants of any event and will be conditions of all private hire

DRUGS POLICY

The management of the premises will not tolerate illegal drugs.

MARKFIELD ARTS

Co.no. 07916106 Regd office: suite 17789,lower Ground floor 145-157 st. John street EC1V4PW

Individuals will be searched on entry.

Any persons deemed to be selling drugs will be detained and handed to the authorities.

Illegal drugs will be confiscated, and handed over to the authorities.

Seizure records will be maintained by security.

No nitrous oxide.

There will be no legal highs for sale on site.

Anybody who refuses to cooperate with our security personnel could lead to exclusion or eviction from the site.

Security and stewards shall be instructed to report to management any person found to be in possession of illegal substances (as defined under the misuse of drugs act). Any such individual shall be denied access to the event and the matter referred to the Police.

All Incidents shall be reported using the Security reporting forms.

Example reporting form:-

MARKFIELD ARTS

Co.no. 07916106 Regd office: suite 17789,lower Ground floor 145-157 st. John street EC1V4PW

INCIDENT REPORT FORM

DATE:

VENUE:

NATURE OF INCIDENT.....

EMERGENCY SERVICES CALLED

Y N please circle

IF YES PLEASE GIVE

DETAILS.....

REPORT

CONTINUE OVER LEAF IF NEEDED

ACTION TAKEN

FILLED OUT BY..... SIGN.....

SIA NUMBER.....

2.5 WEAPONS AND DRUG SEARCHES

MARKFIELD ARTS

Co.no. 07916106 Regd office: suite 17789, lower Ground floor 145-157 st. John street EC1V4PW

The security team will carry out compulsory searches of patrons at the main entrance to the premises prior to entering the building.

2.6 STEWARDING

See appendix D Security and Stewards

This provision has been made in recognition that the safe and efficient running of any event at the premises and the management of an emergency situation will depend greatly on the calm and informed actions of the stewards.

Stewards will be issued with Hi-visibility waistcoats

Maintaining the no smoking policy

Being a source of information

Being aware of general site safety and hygiene i.e. alerting site management of any broken glass or rubbish

The general well being of the public

Stewards will be briefed in the following:

Chain of command

Emergency and evacuation procedures

Fire safety

Use of safety equipment

Use of radio communication equipment

Health and safety on site

Manual handling and approach

There will be evacuation briefings for all personnel before opening to the public.

3.0 PUBLIC SAFETY

An assessment has been undertaken of the potential hazards involved in;

- Site suitability
- Access and exits
- Transport links
- Movement of vehicles
- Safe loading and manual handling
- Production area safety and procedures
- Safe rendezvous points/emergency areas
- Food hygiene and standards
- Drinking water
- Competency of contractors
- Security provision
- Stewarding levels
- Waste disposal
- Sanitary provision

3.1 PREMISES SITE SUITABILITY

The building is a recently refurbished single story industrial unit of brick construction. It has emergency exits to front and rear, Non-residential with good loading of production equipment through a large roller shutter

Good transport links with secure parking for production vehicles.

3.2 SITE ACCESS AND EXITS

Build phase access

Marshalled ingress and egress will be through the main gate directly on and off the site without undue need for queuing, allowing deliveries and workers to access the public highway safely.

Emergency Entrance

Emergency vehicle access is through main gate which leads directly into the premises site.

3.3 ARRIVAL OF PATRONS

Numbers and arrival times will be identified on an hired by hired basis

3.4 TRAFFIC MANAGEMENT PLAN

It is expected that the activities at the premises will have a manageable impact on the roads leading to the premises. Ingress and egress will be marshalled and a banksman will be used for all vehicle movement. An in depth traffic management and pedestrian management plan will be formulated after consultation with Haringey Council safety officer.

See Traffic management plan in appendix P Site and area plans

3.5 PEDESTRIAN EMERGENCY EXITS

It has been assessed by a fire safety consultant adequate exits can be made to deal with a capacity of 930

See Appendix B Fire Risk assessments

3.6 FOOD HYGIENE STANDARDS AND CATERING

Markfield Arts Ltd is committed to food hygiene and safety standards and work with the food standards agency and local environmental health officer to ensure compliance and best practice.

The caterer's Information process is designed to assure quality throughout all events. Caterers are required to produce documentation to ensure competence. Any caterers that do not meet any of the criteria or standards set out in the information will find themselves excluded from an event. Hard copies of all documents will be held at the site office.

Documents required

1. A completed information form
2. An up to date insurance certificate
3. Hygiene Certificate
4. Risk assessments / HACCP / Food standards agency log
5. P.A.T. Certificates,
6. Any relevant fire proofing certificates
7. Gas Safe certificate LPG (where applicable)

A daily opening café is planned see café, operations manual

For information Process see appendix G Caterers and Traders

This appendix will change on an hired by hired basis

3.8 DRINKING WATER

There is mains water supply to the kitchen area. Bottled drinking water will be made available to staff and patrons

3.9 WASTE MANAGEMENT

The waste management plan is based upon experience and previous successful events, and planning

Regular rubbish collections will be made at all events at the premises to avoid build-up of combustible materials

There will be ample rubbish bins across site.

Removal from site Rubbish collections will be made by a registered waste disposal company

All efforts will be made to recycle waste.

MARKFIELD ARTS

Co.no. 07916106 Regd office: suite 17789, lower Ground floor 145-157 st. John street EC1V4PW

There is a no glass policy on site and this will be enforced by stewards, security and the management team...

The fire-proofing agent used on site is water based and the data sheets will be kept at site office

Grey water will be disposed of at the end an event at the premises in line with acceptable environmental practices

Ample Bins will be placed outside the premises during times of an event to aid in the prevention of rubbish spreading into the surrounding area

The roadways and surrounding area will be clean of any rubbish resulting from any event.

Signage will be in clear view



See appendix Q Waste Management

4.0 THE PREVENTION OF PUBLIC NUISANCE

In order to prevent public nuisance Markfield Arts Lld will conducted an assessment of the potential sources of nuisance and will implement the following measures;

- Sound management plan
- Traffic management plan
- Waste management plan
- Internal communication
- Complaints procedure
- Signage

4.1 SOUND MANAGEMENT PLAN

See appendix H Sound Management

This appendix will change on an hired by hired basis

All sound management will adhere to the conditions of the premises licence.

Some of our clients activities will involve amplified sound. Consideration will be given to the location of the systems on site in relation to the location of the nearest residential properties. The sound management plan is built on successful management plans and control measures from previous licenced events.

All sound systems shall be of an appropriate size in order to prevent nuisance to the wider community.

MARKFIELD ARTS

Co.no. 07916106 Regd office: suite 17789, lower Ground floor 145-157 st. John street EC1V4PW

All sound systems will be staffed by competent personnel that shall report to production manager who shall report directly to the duty site manager and management.

Sound system tests

The testing of the sound systems and the setting of output levels shall be carried out in conjunction with the guide lines set by Haringey Council

The test of sound systems will be scheduled prior to use in order to correct sound output levels and control any sound overspill and shall involve a monitoring team. The monitoring team shall be positioned both within the premises and at points close to the boundaries of the nearest residential properties.

Sound output levels

No noise shall be audible at the façade of any residential property in the vicinity

Adequate and competent staff shall be made available to monitor potential sound over-spill using an inaudibility test at a point close to the boundaries of the nearest properties at scheduled times.

This shall NOT apply to amplified broadcasts made in connection with evacuation of the premises in the event of fire or other emergency.

The sound monitoring team shall report directly to the duty site manager

Results from sound monitoring shall be recorded in a dedicated sound monitoring log book. The log shall contain;

- The name of the responsible individual
- The result of the sound sampling either- high /low or inaudible
- Any action required
- Weather conditions
- The time and date of the sound sampling.

4.2 SOUND MONITORING

See appendix H Sound Management

The sound monitoring teams shall be comprised of competent and responsible persons with some experience of sound equipment.

The sound monitoring teams shall be provided with;

- A high visibility vest for offsite readings
- A sound monitoring log

Outside the premises

- monitoring at sample locations outside the premises on a hourly basis
- advise the duty site manager of any increases in sound output levels

- advise the duty site manager of any unwanted or stray frequencies (particularly low or bass frequencies)
- advise the duty site manager of any unwanted or unauthorised sound output (such as car stereo systems)

Inside the premises

The sound monitoring teams shall

- Conduct themselves in a safe and reasonable manor as representatives of Markfield arts
- Report increased sound output directly to the duty site manager
- Report unwanted frequencies directly to the duty site manager
- Report any other unwanted circumstances directly to the duty site manager

The sound monitoring teams

- Conduct themselves with due care and consideration for the residents of those properties close to the premises when conducting outside sampling.
- Communicate via the site radio network during day light hours or mobile phone txt message if they are close to a property at noise- sensitive times.

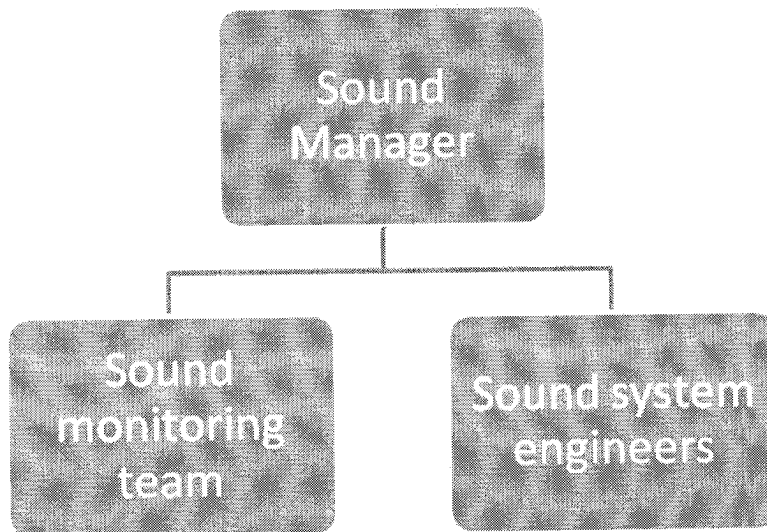

Hierarchy of sound management:

The Sound manager shall instruct the sound System engineers to adjust output as required to allow for changing weather and conditions and to prevent public nuisance.

4.3 INTERNAL COMMUNICATION

Internal communication is essential for the safe and effective management of the premises. Communication during any event shall be via two way radio and mobile

MARKFIELD ARTS

Co.no. 07916106 Regd office: suite 17789, lower Ground floor 145-157 st. John street EC1V4PW

phone network. Contact details for all stake holders including emergency service numbers and radio channel allocation along with mobile numbers shall be held at the site office in plain view. A sign in sign out register of radio equipment including radio channel allocation shall be held at the site office

4.4 COMPLAINTS PROCEDURE

A dedicated complaints line shall be in operation and adequately staffed at all times for the duration of the hired activities. The complaints line number shall be made available to local residents. A complaints log will be kept at the site office and shall be compiled by a competent person detailing;

- The time and date of the problem
- The location of the problem
- The nature of the problem
- The action taken to resolve the problem
- The name of the person responsible for remedial action
- The time and date action was taken

The nominated person/s shall report directly to the duty site manager. The duty manager shall have overall responsibility for dealing with complaints.

5.0 THE PROTECTION OF CHILDREN FROM HARM

Activities involving children and young people under the age of 18 will be free of any supply of alcohol

Security personnel to challenge patrons they suspect of being under 18 on 18+ events at points of entry

All people instructing or directly engaging with children will have an enhanced CRB check.

All children will in the first instance be the responsibility of their parents/guardian/teacher/instructor but should a child become separated from their parents/guardian/teacher/instructor the following procedure will be taken

Any member of staff either finding or being asked to find a lost children should notify the Management immediately. If a lost child is found then the relevant steward or company representative should inform the Management of their exact location. They should also provide as much information as possible. The child and steward should proceed toward the site office whereupon the child should be left in the care of our medical/welfare/managment (CRB). No information about the child should be made public. In the event of a reported lost child the site will go into lockdown and all persons leaving the site in the company of a child must verify theirs and the child's identity

After 10 minutes any reported lost children who has not been reunited with their parents or guardian the local authorities will be then be notified. All plans involving children will be further formulated will consultation with Haringey council child protection services

5.1 ADMISSIONS POLICY

All private hire clients will be issued with wristbands prior to any event/hire

To gain access to the site a wrist band must be obtained .Markfield Arts staff will be briefed in the admissions policy and will be the first check for age identification on 18+ only events

- Challenge 21 posters will be on display at the entrance to the building and bars, and they say
- **“If you are lucky enough to look under twenty one you will be asked to prove that you are over 18.**

The message is designed to be simple, direct and in plain language

5.3 REFUSAL OF ENTRY

The premises management team shall not grant entry to any individual who is;

- Under 18 years of age
- Intoxicated on drink or drugs
- Displaying aggressive or anti-social behaviour
- Believed to have criminal intentions

6.0 EMERGENCY PROCEDURES AND ROLES

EVACUATION PROCEDURE

Illuminated exit signs located at each exit. Emergency lighting is installed throughout the building. Security, stewards and premises management personnel in an emergency situation will direct patrons.

See appendix E Signage

6.1 THE ROLE OF THE POLICE

It is not expected that the Police will be involved in the routine management of any activities at the premises. The Police will be contacted in the event of an emergency by DPS or his acting deputy.

6.2 THE ROLE OF AMBULANCE SERVICE

Markfield Arts Ltd will liaise with the local Ambulance service to determine response times and contingency arrangements and Medical cover.

6.3 THE ROLE OF THE FIRE BRIGADE

It is not expected that The Fire Brigade will need to implement any special arrangements for any activities at the premises. The premises management will deploy adequate fire fighting and safety equipment to cope with untoward incidents.

6.4 EMERGENCY MANAGEMENT PROCEDURES

UNTOWARD INCIDENT

An untoward incident is defined as “a routine occurrence that impacts upon the safe running of the premises but does not require the Police to assume the co-ordination of its resolution.”

Despite effective planning there may still be occurrences determined as untoward incidents. However, it is recognised that if the premises Management Team do not address such circumstances effectively, a more serious Emergency may result.

Resolution of such routine occurrences is an intrinsic part of the Management of the premises. Given their predictability, appropriate Contingency arrangements have been identified and will be managed by the Management Team. To resolve untoward incidents the Management Team will initially communicate by radio/mobile phone. On the occurrence of an Untoward Incident or Emergency situation, the duty site manager will manage the response of the Stewards and Officials in conjunction with the Security Liaison Officer.

An Untoward incident will require a localised response which should not require a general broadcast.

The premises Management Team may retain responsibility for coordination of the response even if Emergency Services assistance has been requested. However the Police may decide that circumstances require further intervention. The premises Management Team will then provide assistance to the police as required.

6.5 EMERGENCY RESPONSE PLAN

An Emergency situation is defined as

“An occurrence that poses a threat of serious injury, loss of life or a break down in public order and does require the Police to assume the co-ordination of its resolution”

Whilst the premises Management Team is responsible for dealing with untoward incidents, those involved must be aware of their own ability to cope and recognise the occurrence of Emergency Situations. If the premises Management team are not able to deal with the incident they should immediately contact the police and/or contact the Emergency Services by telephone. The meeting point will be the site office where a clear plan of action will be determined. In such circumstances, responsibility for coordination of the response will pass to the Police.

On the occurrence of an Emergency Situation, the duty site Manager and the Security Liaison Officer shall assist in communication of essential information to stewards, Officials and members of the public.

All stewards and officials will have a thorough understanding of the contingency arrangements.

MARKFIELD ARTS

Co.no. 07916106 Regd office: suite 17789, lower Ground floor 145-157 st. John street EC1V4PW

A flexible Emergency response plan will be implemented as follows:

Any steward or official becoming aware of an untoward incident or emergency situation must advise their security liaison officer as soon as possible.

State the Location, Incident, Report, and Action.

On receipt of this information the security liaison officer will advise the duty site Manager and/or the Safety Officer (depending on who is the most appropriate person) who will act as appropriate then conduct an assessment to determine if the circumstances do in fact amount to a potential Emergency Situation. If assessed as such The Emergency response Plan will be implemented. Otherwise the occurrence will be managed as an untoward incident.

If the performance has to be stopped a message shall be communicated via the site radio system to security and stewards to begin the evacuation procedure. The message shall be, "Attention, attention, attention. This is not a drill. Please begin the evacuation procedure."

The security that would have been familiarised with the light switch locations will turn the lights on

Sound engineers who have been briefed to comply with requests from security and management with then turn the sound systems off

Stewards will then direct patrons to the emergency exits

A broadcast of clear and concise instructions to the crowd is to be made using the show Public Address system. A microphone shall be connected in such a way as to be instantly available for use in addressing patrons in an emergency situation. Security Liaison Officers also have loud hailer's available. Public co-operation should be requested and some reasoning behind the shut down and subsequent evacuation explained. The message must be concise. Public should be requested to leave as quickly and calmly as possible following stewards instructions to the designated rendezvous point.

Message will be along the following lines;

**Ladies and Gentlemen, we are sorry that due to (insert a brief explanation if appropriate) the show cannot continue.
Please leave the area by any available exit. Please do not approach the Fire engine, stage area/burning structure.
Thank you for your co-operation.
Please follow the steward's directions and leave as quickly and calmly as possible for the designated rendezvous point.**

MARKFIELD ARTS

Co.no. 07916106 Regd office: suite 17789, lower Ground floor 145-157 st. John street EC1V4PW

Stewards and Police Officers (if in attendance) will actively encourage the crowd to move in accordance with the announcement. They will attempt to reassure and calm the crowd. Stewards should indicate with arm gesture (straight arm pointing steadily) to the nearest exit, which will be clearly signposted and from there to the designated rendezvous point. Radio traffic will be restricted. If an evacuation of part or the entire site is required, Stewards and Police Officers will prevent re-entry. It is recognised that circumstances may be such that a major incident may have to be declared. In such circumstances it is the duty of the management to assist the Police as directed.

MAJOR INCIDENT

A Major Incident being defined as;

“Any emergency that requires the implementation of special arrangements by one or more of the Emergency Services, the NHS or the Local Authority for: The initial treatment rescue and transport of a large number of casualties. The involvement of either directly, or indirectly large numbers of people. The need for large scale combined resources of two or more of the Category 1 responders. The mobilisation and organisation of the Emergency Services and supporting organisations, e.g. Local Authority, to cater to the threat of death, serious injury or homelessness to a large number of people.”

The declaration of a major incident will be determined by one or more of the Emergency Services and is beyond the scope of the premises management

It is recognised that circumstances may be such that a major incident will have to be declared.

In such circumstances it is the duty of the premises management to assist the Police as directed.

6.6 FIRE PRECAUTIONS AND EQUIPMENT

There are smoke detectors fire alarm points fitted to the building

Fire points.

All fire points will be positioned as a result of the fire risk assessment and shall be placed in risk identified areas.

All fire points will have the appropriate signage.

Fire Marshalls who are fire extinguisher technician qualified will be on site throughout any hired activity at the premises

Class A Fire points shall consist of

One water fire extinguisher or one foam fire extinguisher. Or both

Fire points class A fires	
Area	Quantity
Public Area room 1	3
Public Area room 2	2
Public Area room 3	1
Box Office	1
Smoking area	1

Electrical fire protection points

Where electrical equipment is used appropriate fire protection shall be in place close to the equipment in order to deal with an incident quickly.

Electrical fire protection will consist of; One Co2 fire extinguisher, or one powder fire extinguisher.

Fire protection points for electrical fires	
Area	Quantity
Production Areas room 1	1
Production area room 2	1
Bar areas	1
Extra units available on site	1
Site office	1

There will be a fire extinguisher and fire blanket installed in cafe area when in use
 Personnel will be briefed by the site safety officer as to the location of fire points as part of the briefing and rehearsal schedule.

Any client's promotional stalls and outlets will be advised that they must have a suitable fire extinguisher.

All clients involving the supply of food and light night refreshments are advised as part of the information process that they must have a light duty fire blanket and a suitable fire extinguisher.

Any fire protection equipment brought to premises will be inspected by the duty site manager prior to opening to the public. Any caterers, traders or stalls arriving without adequate fire protection equipment shall not be permitted on to the premises

Bar areas

The bar area shall have one Co2 fire extinguisher, or one powder fire extinguisher.

6.7 MEDICAL COVER AND FIRST AID PROVISION

Build and break down

The management team will provide suitable first aid protection during the build and breakdown phases for all personnel working on site, including the provision of first aid boxes and eyewash stations and the nomination of sufficient numbers of relevantly trained first aiders to adequately cover those working on site including volunteers and visitors.

A first aid kit containing;

- Sterilised cleaning strips
- Plasters
- Scissors
- Eyewash
- Gloves

A first aider will be on duty at all times during build and break down phases.

Details of nominated first aiders shall be held at the site office.

An accident book shall be kept at the site office which will be compiled by a competent person

Running Times

All provisions will be made with reference to HSE guidance and consultations with local NHS St Ann's Hospital

See appendix K Medical

6.8 EVENT CONTROL

The client's event control shall be positioned in the site office

6.9 INSURANCE

See appendix J Insurance

All activities on the premises will be fully insured

Insurances will include;

- Employer's liability insurance
- Public liability insurance
- Products liability

7.0 COMPETENT CONTRACTORS AND CREW

All contractors and sub-contractors shall produce evidence of competency in addition to suitable and sufficient risk assessments/method statements for their work task and a current insurance certificate with the required amount of cover.

All contractors and sub-contractors and crew are expected to adhere to premises rules and to cooperate with others whilst conducting themselves and their operations in a way which promotes their own safety and that of others. The contractor's and crew information process is designed to assure consistency throughout.

Contractors are required to produce documentation to ensure competence.

Any contractors that do not meet any of the criteria of standards set out by in the Information process will find themselves excluded from Markfield Arts. All documents will be held at The site office.

See appendix L Terms and conditions

7.1 ELECTRICAL SUPPLIES AND INSTALLATIONS

There is an adequate electrical supply on site to accommodate all proposed needs

There are ample electrical sockets throughout. Sockets when not in direct use or public areas sockets will be isolated or inaccessible by the employment of blanking plates

Any installations introduced will be by competent contractors

All equipment arriving on site will be checked for a current pat certificate

Electrical contractors to PAT test equipment prior any operation to ensure that any items not bearing a current PAT certificate may be tested and certificated.

Electrical contractors to PAT test equipment prior any operation to ensure that any items not bearing a current PAT certificate may be tested and certificated

See appendix O electrical supply

7.2 SHOW LIGHTING

A briefing on the correct use of ladders will be taken with Guidance from working at height

A ladder registry will be in force

Risks will be assessed before work commences

Methodology will be documented and kept at the premises site office

All documents concerning lighting will be logged in appendix on a hired by hired basis

MARKFIELD ARTS

Co.no. 07916106 Regd office: suite 17789, lower Ground floor 145-157 st. John street EC1V4PW

Production lighting will be introduced on an hired by hired basis

Only Component contractors to be used

Suitable light fixtures will be installed all temporary lighting installations will be assessed for safety and correct cable ties and fixings assessed for breaking strain

See Appendix N Show Lighting and décor

This appendix will change on an hired by hired basis

7.3 INTRODUCTION OF EXHIBITS

The weight of each exhibition piece will be assessed and the correct fixings with the suitable braking strain will be used

A briefing on the correct use of ladders will be taken with Guidance from working at height

A ladder registry will be in force

Risks will be assessed before work commences

Methodology will be documented and kept at the premises site office

8.0 SANITARY PROVISION

The building is equipped with 3 toilets which is ample for small events

Provision for porta loos will be made on an hired by hired basis referring to HSE guidance

9.0 TEMPORARY INSTALLATIONS AND STRUCTURES

All installations and temporary demountable structures will checked for safety before being opened to the public all checks will be logged and documents will be kept at the site office

Safe standards of work will be in force throughout all operations

Safety induction briefings will be given to all participants of all organisations working on the premises

10.0 SIGNAGE

See appendix E Signage

- Signage for the building will be made in compliance with the health and safety (signs and signals) regulations 1996.
- Guidance has been taken from Hsg L64.
- There will be ample directional signage

MARKFIELD ARTS

Co.no. 07916106 Regd office: suite 17789, lower Ground floor 145-157 st. John street EC1V4PW

- All Caterers have been notified to the needs of relevant signage in their information process

See appendix G Caterers & Traders

This appendix will change on a hired by hired basis

11.0 LOAD IN AND LOAD OUT

The following legislation dictates our working practice:

- The Manual Handling Operations Regulations.
- The Lifting Plant & Equipment Regulations.
- Personal Protective Clothing.

All equipment will be delivered to the site, will be all times be marshaled by banksman

De-rigging and equipment removal will be done as per the above.

Unloading and loading of equipment /materials

Size & weight of equipment to be assessed to avoid strain from lifting/moving of heavy objects, falling equipment from stacked loads, falling on toes etc.

Preventative measures:

- 1) All crew supervised by a competent person.
- 2) All crew to be competent in the task they are asked to perform.
- 3) Access areas to be kept clear where possible.
- 4) Adequate number of personnel and equipment used to maneuver large/heavy equipment.
- 5) Loading ramps to be used where appropriate. Mechanical lifting aids will be used when equipment is too heavy to lift by hand
- 6) All staff and contactors are advised on the use of PPE.
- 7) De-rigging and equipment removal will be done as per the above

12.0 Decoration/ structures

See Appendix N Show Lighting and decor

This appendix will change on an hired by hired basis

A briefing on the correct use of ladders will be taken with guidance from working at height.

A ladder registry will be in force

Risks will be assessed before work commences

Methodology for safe working will be documented and keep at the site office

Methodology on the use of fire retardant materials will be documented and keep at the site office

See Appendix b Fire risk assessments

13.0 Market area and Traders

The Traders application process is designed to assure quality throughout the event. Traders are required to produce documentation to ensure competence. Any Traders that do not meet any of the criteria of standards set out by in the application will find themselves excluded from the event. Copies of documents will be held at the site office

Documents required.

1. A completed application form
2. An up to date insurance certificate
3. Risk assessments
4. P.A.T. Certificates
5. Any relevant fire proofing certificate

We will have facilities for PAT testing on site

For application Process for Traders see appendix G Caterers and Traders

14.0 Documentation and reporting

Hardback books will be kept at site office to keep records for

Incidents log

Accidents log

Copies with any additions of the operations will be made available and will be held at the site office

Site management will keep their reporting procedures and housekeeping logs

Security will keep their reporting procedures

See appendix D Security and Stewards

15.0 SITE SAFETY RULES

Site safety rules and signage shall be displayed in a prominent position across the site.

All persons on site during the build phase shall be made aware of the site safety rules at their site induction.

Site safety rules

1. Contractors, crew and visitors to site must take every care when parking their vehicle not to cause a hazard on the public highway or to themselves,

- workers from other companies or members of the public and must park as directed.
2. Appropriate foot ware must be worn at all times on site.
 3. High visibility vests or clothing must be worn at all times during the build and breakdown phases. During show time all personnel who are not on duty must remove their high visibility clothing.
 4. Contractors, crew and visitors to site are required to conduct their activities at the event site so as not to cause a hazard to themselves or others. This includes the use of personal protective equipment or the production of method statements if required. Particular attention must be paid to the safety of the public.
 5. The playing of radios, sound systems or any amplified or acoustic music is prohibited unless for the purpose of a sound test or similar and or with the written permission of the organisers.
 6. All hand tools, plant or equipment used on site must be suitable for the purpose and in a sound and safe condition.
 7. Any electrical equipment used in testing or measuring must bear a current PAT certificate.
 8. Contractors crew and visitors to site are required not to leave any rubbish or Waste material on the premises.
 9. In an emergency situation all contractors, crew and visitors to site must follow instructions from stewards and security and leave the event arena immediately for the RVP and must not return to collect any personal items from inside the premises

16.0 ACCREDITATION

Wrist bands and lanyards will be employed to aid the premises management and all clients, to control access to and allow accurate information in the event of an emergency

17.0 CCTV

CCTV will be in operation inside and outside the Premises 24hrs.

APPENDIX 2 – METROPOLITAN POLICE REPRESENTATION



Working together for a safer London

POLICE REPRESENTATION

Name and address of premises:

Markfield Arts Ltd, 100 - 108 Markfield Road N15

Type of Application: New Premises Licence.

I wish to make representation on the following:

- Prevention of crime and disorder

If this application were granted in full or part, I would recommend the following alterations be made to the licence conditions. I also suggest that additional conditions be attached to the licence, as set out below, to further promote the licensing objectives.

	Current Conditions	Recommendation
1	CCTV System will be installed.	<p>A digital CCTV system to be installed in the premises.</p> <p>Cameras must be sited to observe the entrance doors from both inside and outside. Rear exit door also covered from inside by camera.</p> <p>Cameras on the entrances must capture full frame shots of the heads and shoulders of all people entering the premises i.e. capable of identification.</p> <p>Provide a linked record of the date, time, and place of any image.</p> <p>Provide good quality images - colour during opening times.</p> <p>Have a monitor to review images</p>

		<p>and recorded quality.</p> <p>Be regularly maintained to ensure continuous quality of image capture and retention.</p> <p>Staff trained in operating CCTV.</p> <p>Digital images must be kept for 31 days. The equipment must have a suitable export method, e.g. CD/DVD writer so that Police can make an evidential copy of the data they require. Copies must be available within a reasonable time to Police on request.</p>
<p>2</p> <p>3</p>		<p>It is policy in Haringey for venues to stop serving alcohol 30 minutes before venue closed to the public to allow a cooling down drinking up period.</p> <p>A minimum of 6 S.I.A registered security staff to be present during music / dance events from time venue opens to the public until it closes. This number will increase by 1 S.I.A Security Officer per 100 clients present should the total persons in the venue exceed 600. A male and female on the front entrance with metal detector 'wands' scanning all entrants and 'pat down' searches of all entrants. One officer covering rear door and one controlling queues outside venue.</p> <p>Security personnel, including: patrols outside the venue to control queuing customers, ensuring the SIA</p>

4		<p>staff are appropriately monitored by the management of the premises, ensuring that toilets are monitored by a member of staff at least once every 30 minutes (and such monitoring to be logged in writing and made available to police on request).</p> <p>An incident log shall be kept at the premises, it will be in a hardback durable format handwritten at the time of the incident or as near to as is reasonable and made available on request to the Police, which will record the following:</p> <ul style="list-style-type: none">(a) all crimes reported to the venue(b) all ejections of patrons(c) any complaints received(d) any incidents of disorder(e) seizures of drugs or offensive weapons(f) any faults in the CCTV system or searching equipment or scanning equipment(g) any refusal
---	--	-------------------------------------------------------------------------------------------------------------------------------------------------------------------------------------------------------------------------------------------------------------------------------------------------------------------------------------------------------------------------------------------------------------------------------------------------------------------------------------------------------------------------------------------------------------------------------------------------------------------------------------------------------------------------------------------------------------------------------------------------------------------------------------------------------------------------------------------------------------------------------------

5		<p>of the sale of alcohol (h) any visit by a relevant authority or emergency service.</p> <p>Form 696 Notification of Promoter / DJ's at events to be emailed to Police as soon as possible, at least 10 working days before event.</p> <p>Any films shown must have a BBFC certificate or be submitted to Haringey Council prior to transmission for certification.</p>
---	--	------------------------------------------------------------------------------------------------------------------------------------------------------------------------------------------------------------------------------------------------------------------------------------------------------------------------------------------------------------------------------

This is under the Protection of Children from Harm Objective.

Challenge 21 Policy Implemented:

I recommend that the following form of verification of a person's proof of age is:

- . valid passport.
- . photo driving licence
- . proof of age standard card system
- . citizen card, supported by the Home Office.

If these conditions were accepted in full I would withdraw my representation.

Officer: Mark Greaves
Licensing Officer Haringey Police

Tel: 020 3276 0150

mark.Greaves@Met.Police.UK

Date: 17th August 2012

**APPENDIX 3 – ENVIROMENTAL HEALTH- ENFORCEMENT RESPONSE
REPRESENTATION**



Licensing Consultation

To: Licensing Officer

From: Enforcement Response Officer (Noise)

Name of Officer preparing representation: Mark Eastwood

cc: Team Leader Enforcement Response, Derek Pearce

Our Reference: WK228428

Date: 8th September 2012

Premises: Markfield Arts Centre, 100-108 Markfield Road, London, N15 4QF

Type of application: **New**

I would like to confirm that I have considered the above proposal with regard to the prevention of public nuisance on behalf of the Enforcement Response (Noise) Team & would like to **make** representations to the Application

The operating schedule does not adequately address the prevention of public nuisance

Further consideration should be given to the operating hours as the noise caused by patrons exiting the premises and locating suitable transport home has the potential to be detrimental to the residential amenity. This may be exacerbated by the level of public transport available when patrons leave

Supporting Information

If the sub-committee were minded to grant their application supporting evidence of the extent of sound insulation should be provided.

A sound management plan approved by Enforcement Response should be prepared and implemented which will include how the Premises Licence holder will liaise with residents and deal with complaints.

A sound limiting device shall be in place before any regulated entertainment takes place under the Premises Licence.

APPENDIX 4 – BUILDING CONTROL REPRESENTATION

Anderson Chanel

From: Barrett Daliah
Sent: 04 October 2012 13:09
To: Anderson Chanel
Subject: FW: LL/0010/0592 - 100-108 Markfield Road N15

From: Villalobos Jamie
Sent: 03 October 2012 09:45
To: Barrett Daliah
Subject: FW: LL/0010/0592 - 100-108 Markfield Road N15

Daliah,

Further to recently submitted information for the above named premises I would like to raise an objection until the outstanding matters are resolved.

Best Regards

Jamie Villalobos
Building Control Surveyor
Building Control

T: 020 8489 5139
M: 07870 157 862
F: 020 8489 5229

From: Villalobos Jamie
Sent: 03 October 2012 09:44
To: 'abhi beltharia'
Subject: RE: LL/0010/0592 - 100-108 Markfield Road N15

Mr Beltharia,

Thank you for your e-mail, however, the proposed uses shown in your licensing application are not fully detailed by the plans that you have deposited.

Furthermore the plans received appear to be the same layout plan with a different use stated on each plan.

Please submit plans and information detailing how you intend to comply with the Technical Standards for Places of Entertainment;

1. Max occupancy level not indicated for each use.
2. Method of closing off areas not detailed. We spoke of temporary partitioning on site, this has not been detailed.
3. Sanitary accommodation not fully detailed.
4. Installations such as bars not detailed.
5. Alterations to the existing electrical system to bring it up to the standard required by Licensing.
6. Ventilation provisions required for proposed use.
7. Any special installations or effects.

Please be aware that this list is not conclusive, you will need to refer to the Technical Guide noted above.

Best Regards

04/10/2012

Jamie Villalobos
Building Control Surveyor
Building Control

T: 020 8489 5139
M: 07870 157 862
F: 020 8489 5229

From: abhi beltharia [mailto:abhi_beltharia@yahoo.com]
Sent: 02 October 2012 10:59
To: Villalobos Jamie
Cc: Chenier Pierre; PAUL BACON
Subject: Re: LL/0010/0592 - 100-108 Markfield Road N15

Dear Mr. Villalobos,
Please see attached Plans indicating each Proposed use applied for.

Each activities will be carried out on its own to assure their is no conflict of interest.

Thanks & Regards

Abhishek Beltharia

From: Villalobos Jamie <Jamie.Villalobos@haringey.gov.uk>
To: 'abhi beltharia' <abhi_beltharia@yahoo.com>
Cc: Chenier Pierre <Pierre.Chenier@haringey.gov.uk>
Sent: Tuesday, September 25, 2012 4:48 PM
Subject: LL/0010/0592 - 100-108 Markfield Road N15

Dear Mr Beltharia,

Further to the submission of drawings and details I require layout plans indicating each proposed use of the proposed licensed premises, in accordance with the technical guidance for the Licensing Act 2003.

Should you wish to discuss this matter further please contact me using the details below.

Best Regards

Jamie Villalobos
Building Control Surveyor
Building Control

T: 020 8489 5139
M: 07870 157 862
F: 020 8489 5229

This email and any files transmitted with it are confidential, may be subject to legal privilege and are intended only for the person(s) or organisation(s) to whom this email is addressed. Any unauthorised use, retention, distribution, copying or disclosure is strictly prohibited. If you have received this email in error, please notify the system administrator at Haringey Council immediately and delete this e-mail from your system. Although this e-mail and any attachments are believed to be free of any virus or other defect which might affect any computer or system into which they are received and opened, it is the responsibility of the recipient to ensure they are virus free and no responsibility is accepted for

APPENDIX 5 – LONDON FIRE AND CIVIL DEFENCE AUTHORITY REPRESENTATION



Fire Safety Regulation: North West Area 1
169 Union Street London SE1 0LL
T 020 8555 1200 x38795
F 020 8536 5930
Minicom 020 7960 3629
www.london-fire.gov.uk

Ms D Barrett,
Lead Licensing Officer
Haringey Council Licensing
Techno Park
Ashley Road
London
N17 9LN

London Fire and Emergency Planning
Authority runs the London Fire Brigade

Date 10 September 2012
Our Ref FS/NW/31/10657

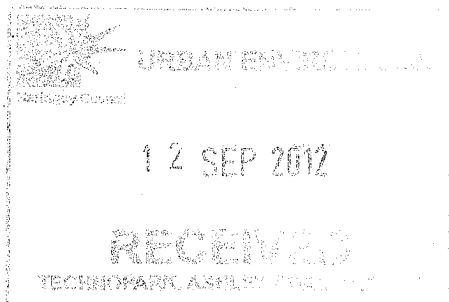

Dear Madam

LICENSING ACT 2003

Premises: Markfield Arts Ltd., 100-108 Markfield Road, London N15 4QF

With reference to the application dated 16th August 2012, as shown on plan number 2519 Rev A, the application has been examined and **the Fire Authority want to make a representation** to the Licensing Authority in relation to this application.

The applicant has been informed that the Fire Authority will be making a representation to the Licensing Authority.

The items that are of concern to this authority are detailed on the attached schedule.

Please advise me, at your earliest convenience, of the date and time of the Licensing Committee Hearing.

Should these matters be resolved to the satisfaction of this Authority at least 2 days prior to the Licensing Committee Hearing the representation will be withdrawn.

Any queries regarding this letter should be addressed to the person named below. If you are dissatisfied in any way with the response given, please ask to speak to the Team Leader quoting our reference.

Yours faithfully,

A handwritten signature in black ink, appearing to read 'K. Close'.

for Assistant Commissioner (Fire Safety Regulation)
Fire and Community Safety Directorate
firesafetyregulationNW@london-fire.gov.uk

Reply to Kevin Close
Direct T 020 8555 1200 Ext 38256



SCHEDULE

Sheet 1 of 1

Schedule referred to in the letter reference FS/NW/31/10657 under the Licensing Act 2003, issued by the London Fire and Emergency Planning Authority on 10 September 2012.

Where appropriate, a plan may form part of this Schedule to illustrate the steps which, in the opinion of the fire authority, need to be taken in order to promote the public safety objective.

NOTE : Notwithstanding any consultation undertaken by the fire authority, **before** you make any alterations to the workplace, **you** must apply for local authority building control department approval (and/or the approval of any other bodies having a statutory interest in the premises) if their permission is required for those alterations to be made.

Licensing Objective not adequately addressed	Location and detail of matters which are considered to put people at risk in the event of a fire emergency	Steps considered necessary to promote the public safety licensing objective
Public Safety	<p>Proposed capacity of 450 is not supported by your calculations.</p> <p>In accordance with your submitted exit calculations and drawing, the small door 'A' within fire risk assessment 'Means of Escape Calculations' is designated as a kitchen area and therefore cannot be utilized as a general means of escape.</p>	In the opinion of the Authority, the premises, as shown on the licensing application documents appears unsuitable for the proposed use(s) and capacity.
Public Safety	<p>Proposal to increase capacity to 930.</p> <p>There is not sufficient available external escape route(s) to match this capacity.</p>	
Public Safety	<p>Submitted application states that crowd control barriers to be inside the front enclosure of the premises.</p> <p>There are no details of the actual location and how these barriers will not adversely effect the means of escape from the property.</p>	
Public Safety	<p>Submitted fire risk assessment highlights numerous fire safety issues.</p> <p>Items highlighted within fire risk assessment action plan to be implemented.</p>	

Public Safety	<p>The submitted application states that the use of the premises will be used for various events.</p> <p>The plans and the fire risk assessment do not indicate location of these different events or structures. These could adversely effect the capacity numbers or the means of escape from the building.</p>	
Public Safety	<p>The submitted plans indicate that there is an open plan store and cloakroom within a means of escape.</p> <p>All exit routes are to be free from items of combustion and protected by a minimum 30 minute fire resisting construction. All doors within these routes should be 30 FDS.</p>	
Public Safety	<p>The submitted plans state secure parking available. If this relates to the small on site parking to the front of the premises, then the parked vehicles could adversely effect the means of escape from the property.</p> <p>To ensure safe exit availability from this property the car park is to remain free of vehicles when the building is occupied.</p>	

Data Protection Act 1998: The information you have given on this form will be processed by London Fire Emergency Planning Authority for the purpose of **fire and emergency planning and control**. We will keep your details secure and will not disclose them to other organisations or third parties (except contractors or suppliers working on our behalf) without your permission unless we are legally required to do so.

For more information about how we use your personal information, see our notification entry (Z7122455) www.informationcommissioner.gov.uk or visit: www.london-fire.gov.uk



**LONDON FIRE
AND EMERGENCY
PLANNING AUTHORITY**

Fire Safety Regulation: North West Area 1
169 Union Street London SE1 0LL
T 020 8555 1200 x38795
F 020 8536 5930
Minicom 020 7960 3629
www.london-fire.gov.uk

Ms Dailah Barrett
Lead Licensing Officer
Haringey Council Licensing
Techno Park
Ashley Road
Tottenham
London
N17 9LN

London Fire and Emergency Planning
Authority runs the London Fire Brigade

Date 20 September 2012
Our Ref FS/NW/31/010657

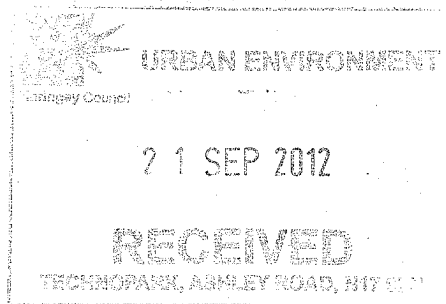

Dear Madam

FIRE SAFETY INSPECTION

Premises: Markfield Arts Ltd, 100-108 Markfield Road, Tottenham, London N15 4QF

The Fire Authority has recently carried out an inspection of the above-mentioned premises.

During the inspection, deficiencies relating to public safety were noted. These matters are specified in the schedule attached to this letter. The Authority recommends that, before renewing / granting the licence, you take action to ensure that the applicant has resolved these matters.

If there are specific fire safety matters about which you are concerned or you have any queries regarding this letter, please contact the person named below. If you are dissatisfied in any way with the response given, please ask to speak to the Team Leader quoting our reference.

Yours faithfully,

for Assistant Commissioner (Fire Safety Regulation)
Fire and Community Safety Directorate
firesafetyregulationNW@london-fire.gov.uk

Reply to Mike Howlin
Direct T 0208 555 1200 Ext 38251



**LONDON FIRE
AND EMERGENCY
PLANNING AUTHORITY**

Fire Safety Regulation: North West Area 1
169 Union Street London SE1 0LL
T 020 8555 1200 x38795
F 020 8536 5930
Minicom 020 7960 3629
www.london-fire.gov.uk

Mr Abhishek Beltharia
Markfield Arts Ltd
100-108 Markfield Road
Tottenham
London
N15 4QF

London Fire and Emergency Planning
Authority runs the London Fire Brigade

Date 20 September 2012
Our Ref FS/NW/31/010657

Dear Sir

REGULATORY REFORM (FIRE SAFETY) ORDER 2005
NOTIFICATION OF FIRE SAFETY DEFICIENCIES

Premises: Markfield Arts Ltd, 100-108 Markfield Road, Tottenham, London N15 4QF

A recent inspection of the above premises by a fire authority officer revealed that certain conditions specified in and required by the Regulatory Reform (Fire Safety) Order 2005, were being contravened.

The Authority considers that the steps detailed in the attached schedule need to be taken in order to comply with the above legislation.

The steps should be completed by **4 October 2012** when a further inspection may be carried out.

You should note that failure to comply with any requirement of the legislation is an offence and the person responsible is liable to prosecution. This letter and attached schedule are issued without prejudice to any legal action which may subsequently be taken regarding the failures to comply with the Legislation.

Your attention is drawn to the notes attached.

The contents of this letter are without prejudice to any requirements or recommendations that may be made by the Authority under the Petroleum (Consolidation) Act 1928, or either the local authority or the Health and Safety Executive under any other Act of Parliament or Regulation for which they are the enforcing authority. Approval will normally be required under the Building Regulations for any building works to be carried out. You are advised that before you commence any building works you are obliged to notify the local Building Control Officer or an approved inspector under the Building Regulations 2000 or the Building (Approved inspectors etc) Regulations, 2000 as amended in 2006 respectively. Regard must also be taken, where applicable of the provisions of the London Building Act (Amendment) Act 1939 as amended.

If you are in any doubt as to the obligations placed upon you by the legislation, or if there is any relevant matter upon which you require clarification you may contact the person named below. If you are dissatisfied in any way with the response given please ask to speak to the Team Leader quoting the above reference.

Yours faithfully,

for Assistant Commissioner (Fire Safety Regulation)

Fire and Community Safety Directorate
firesafetyregulationNW@london-fire.gov.uk

Enc: Form FS03_01b Legislation Extracts

Cc: Mr Abhishek Beltharia, Markfield Arts Ltd, 47 Springfield Road, Thornton Heath, Surrey, CR7 8D2

Cc: Ms Dailah Barrett, Lead Licensing Officer, Haringey Council Licensing, Techno Park, Ashley Road, Tottenham, London, N17 9LN

Reply to Mike Howlin
Direct T 0208 555 1200 Ext 38251

SCHEDULE**PREMISES: Markfield Arts Ltd, 100-108 Markfield Road, Tottenham, London N15 4QF****File Number: FS/NW/31/010657**

This schedule should be read in conjunction with the Authority's letter dated 20 September 2012.

The conditions specified in the Regulatory Reform (Fire Safety) Order 2005, were being contravened and the following steps need to be taken in order to comply with the above legislation:

Article	Area of Concern	Steps Considered necessary to remedy the contravention.
Article 8	Failure to take such general fire precautions as will ensure the safety of persons on the premises.	Implement general fire precautions to the rear of the premises to allow smoking. This could be achieved by 1) Raising the fence to prevent discarded cigarettes from entering neighbouring premises 2) Buckets of sand being made available to be used for discarded smoking products 3) Trained security guards with water extinguishers located at this area to monitor the situation.
Article 9(1)	Failure to make a suitable and sufficient fire risk assessment.	Carry out or amend the fire risk assessment to ensure that this is suitable and sufficient.
Article 10	Where a risk assessment has been undertaken the preventative and protective measures have not been carried out on the basis of the principles specified in Part 3 of Schedule 1. The fire risk assessment action plan is to be completed; also there are fabrics hanging from walls or draped over furnishings in the premises.	Implement preventative and protective measures identified in fire risk assessment on the basis of the principles specified in Part 3 of Schedule 1. Implement the fire risk assessment action plan. Provide compliance certificates for the fire proofing of the various drapes and coverings that will be located within the premises.
Article 13(1)	Failure to provide a suitable method of giving warning in case of fire.	Provide a suitable method of giving warning in case of fire. 1) Visual method of alarm notification (flashing beacons) required at strategic locations throughout premises. These are to be separate from and different to any visual displays used during music events. 2) Additional break glass call points linked to the main fire alarm system, to be located at each exit point.
Article 14(2) (b)	Failure to ensure that, in the event of danger, persons are able to evacuate the premises as quickly and as safely as possible.	Ensure persons are able to evacuate the premises as quickly and as safely as possible. The cloakroom area should be separated from the exit route by 30 minute fire resisting construction.
Article 14(2) (b)	Failure to ensure that, in the event of danger, persons are able to evacuate the premises as quickly and as safely as possible. Currently insufficient exits for required capacity.	Ensure persons are able to evacuate the premises as quickly and as safely as possible. One way to achieve this would be to construct a sound proofed timber structure that will allow the roller shutter to be raised and secured; with double outward openable doors of at least 1700mm wide and fitted with push bars and appropriate signage.

Article 14(2) (b)	Failure to ensure that, in the event of danger, persons are able to evacuate the premises as quickly and as safely as possible.	Ensure persons are able to evacuate the premises as quickly and as safely as possible. The rear sliding door requires to be changed to a outward opening swing door with a push bar opening device, with appropriate 'push bar to open' signage on door(s).
Article 14(2) (b)	Failure to ensure that routes to emergency exits from premises and the exits themselves are kept clear at all times.	Ensure that routes to emergency exits and the exits themselves are kept clear at all times. To facilitate the exit routes there is no parking permitted or other potential obstructions within front car park or immediately outside the entrance gates on the roadway.
Article 14(2) (b)	Failure to ensure that, in the event of danger, persons are able to evacuate the premises as quickly and as safely as possible.	Ensure persons are able to evacuate the premises as quickly and as safely as possible. The raised ground within the rear courtyard exit route has the potential to cause a trip hazard and should be levelled to remove any potential issues.
Article 14(2) (g)	Failure to ensure that emergency routes and exits are indicated by signs.	Ensure that adequate maintained exit signs are provided to indicate emergency routes and exits.
Article 14(2) (h)	Failure to ensure that emergency routes and exits are adequately lit.	Ensure that adequate lighting is provided to illuminate emergency routes and exits, particularly externally at the rear courtyard of the premises and the side exit route.

THE REGULATORY REFORM (FIRE SAFETY) ORDER 2005

Your rights when Fire Safety Inspecting Officers take action.

The fire authority has a duty to enforce the Regulatory Reform (Fire Safety) Order 2005.

If an Inspector:

tells you to do something - you have a right to a verbal and written explanation of what needs to be done and why.

Intends to take immediate action - for example by issuing an enforcement notice this will include a written explanation either forming part of the notice or by separate letter.

Issues a formal notice - you will be told in writing about your right to appeal to a magistrates' court. You will be told:

- ◆ how to appeal;
- ◆ where and within what period an appeal may be brought; and
- ◆ that action required by a prohibition/restriction notice is not suspended while an appeal is pending unless the court so directs.
- ◆ that action required by an enforcement notice is suspended while an appeal is pending.

Issues a Notification of Fire Safety Deficiencies - full discussion should have taken place and agreed improvements to bring the premises up to minimal standards should be formulated. A Notification of Fire Safety Deficiencies carries no statutory force but may result in formal action being considered if the agreed improvements do not take place.

The procedures and rights above provide ways for you to have your views heard. If you are not happy with the inspecting officer's action you should contact the Team Leader on the telephone number shown at the head of the covering letter in the first instance.

APPENDIX 6 – COMMENTS MADE BY PLANNING SERVICES

From: Smith Paul
Sent: 15 October 2012 11:32
To: Anderson Chanel
Cc: Plakop John; Makoon Taylamay
Subject: RE: markfield Arts Limited, 100-108 Markfield Road, London N15

Chanel

This site is currently the subject of an appeal against the refusal of planning permission Hgy / 2012 / 0252. The decision is currently awaited from The Planning Inspectorate, may be a month or so before its made. There have been no other applications submitted since the last application. Thanks Paul

Paul Smith
Head of Development Management
Planning & Regeneration
Tel: 0208 489 5507
email: paul.smith@haringey.gov.uk

APPENDIX 7 – LETTER OF REPRESENTATION FROM ‘OTHER PARTIES’

Anderson Chanel

From: Nadeane Eames-Willis [nadeane67@hotmail.co.uk]
Sent: 02 October 2012 08:34
To: Licensing
Subject: RE: New Premises Application -Markfield Arts, 100-108 Markfield Road, London N15 4QF
my home address

129 Hitcham road

Walthamstow
E17 8HL

From: Licensing.Licensing@haringey.gov.uk
To: nadeane67@hotmail.co.uk
Date: Mon, 1 Oct 2012 12:20:24 +0100
Subject: RE: New Premises Application -Markfield Arts, 100-108 Markfield Road, London N15 4QF

Please can you supply your address to make this a valid representation.

Regards
Daliah Barrett

From: Nadeane Eames-Willis [mailto:nadeane67@hotmail.co.uk]
Sent: 01 October 2012 12:10
To: Licensing
Subject: FW: New Premises Application -Markfield Arts, 100-108 Markfield Road, London N15 4QF

From: nadeane67@hotmail.co.uk
To: licensing@haringey.gov.uk
Subject: RE: New Premises Application -Markfield Arts, 100-108 Markfield Road, London N15 4QF
Date: Fri, 13 Apr 2012 15:55:49 +0000

Dear Sir/ Madam

i would like to object to the application recently submitted at the above address

i work along Markfield Road and feel this is totally not a suitable area for the proposed usage of the building along with the vehicles that are down this road , children use this road as a cut through to go to school which does coincide with times this venue wishes to open ,

the park which is used by young and old children is right by this premises and i can not see how it would be appropriate for young children to see adults leaving a building under the influence of alcohol.

if you would like to discuss this matter further please do not hesitate to contact me

Nadeane Eames- Willis

07745851322

08/10/2012

Sent: 30 September 2012 23:05

To: Licensing

Subject: Licensing application: Markfield Arts Ltd 100-108 Markfield Road, London, N15 4QF Tottenham Green

Dear Madam/Sir

I would like to make representations against the application by Markfield Arts Ltd for the proposed use of 100-108 Markfield Road, London, N15 4QF.

I live a couple of hundred metres away from the premises, but I go past them every day as Markfield Park is where I go for a run every morning. The organisers have been running events at the premises regularly since the organisers' last licence application was rightly turned down. They seem just to run raves; I suspect they don't have much interest in any of the other things they're applying for a licence for - they might just be a smokescreen to give the impression it will be an arts venue as opposed to a full-on, round the clock venue for warehouse raves.

The events cause significant public nuisance and risk. The noise is relentless, and pounds for up to twelve hours a time. Litter, including broken bottles, is left strewn around and people attending events often choose to relieve themselves in the street rather than in the venue. Wasted-looking people hang around, standing and talking, sitting on the ground or shouting at each other outside the venue. On one Sunday morning while an event was going on there was pretty open drug dealing taking place in Markfield Park, to which it is very close. Holding events at this location deters people from using the park. I talk to other early morning users of it, and they are anxious about the people hanging around, noise, litter and drug-dealing.

It causes nuisance not just around the venue but much further afield, as out-of-it party-goers walk down the residential streets that link the venue to public transport. They talk, shout and chase each other about, sometimes shouting and screaming, all through the night. They come down my road at all hours; they must go past the residential care home in Wakefield Road too disturbing the sick people living there.

Since the last licence application was refused the organisers have made some token efforts to tidy up after the mess their customers cause. However, the nuisance these events cause is completely out of proportion with any benefit they might bring. I do not believe that restricting the proposed centre's times of operation would help in any way to prevent these problems; its location is simply unsuitable for these events. I therefore urge the council to turn down the application in its entirety.

Yours faithfully

(I would be grateful if you did not share my name and address with anyone outside the council.)

loud service.

www.markfieldarts.com

Anderson Chanel

From: CarolineOD@odonovan.co.uk
Sent: 03 October 2012 13:29
To: Licensing; Barrett Daliah
Cc: Anderson Chanel
Subject: FW: 100-108 Markfield Road, N15 4QF

O'DONOVAN
 WASTE DISPOSAL LTD

NORTH
LONDON

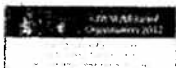

arca **IIRSM** Member

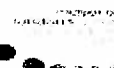

From: Caroline O'Donovan
Sent: 13 April 2012 13:20
To: daliah.barrett@haringey.gov.uk
Cc: licensing@haringey.gov.uk
Subject: FW: 100-108 Markfield Road, N15 4QF

From: Barrett Daliah [<mailto:Daliah.Barrett@haringey.gov.uk>] **On Behalf Of** Licensing
Sent: 12 April 2012 17:47
To: Caroline O'Donovan
Subject: RE: 100-108 Markfield Road, N15 4QF

Hello Caroline

Please provide the address of your premises to make this a valid representation.
 Many thanks
 Daliah Barrett

From: CarolineOD@odonovan.co.uk [<mailto:CarolineOD@odonovan.co.uk>]
Sent: 11 April 2012 21:09
To: Licensing
Cc: Anderson Chanel
Subject: 100-108 Markfield Road, N15 4QF

Caroline O'Donovan
 82/98 Markfield Road
 Tottenham
 London
 N15 4QF

Dear Ms Barrett-Williams

04/10/2012

I am writing to lodge a very strong objection against the application of a premises license for the above property under the name of the Markfield Arts Ltd.

I work in a local business that will be and has already been affected by the events run at this address by the company known as Markfield Arts Ltd. This company has now held two events the first one being illegal and the second one with what I believe to be a Temporary Events Notice. Markfield Arts Ltd has already sent an application in to Haringey to achieve a change of use from a commercial unit to an exhibition centre this application has subsequently been turned down by Haringey we do not believe that Markfield Arts Ltd never intend to hold exhibitions of any kind but events such as trance dance events as Mr Beltharia also has an interest in a trance music company <http://www.abhitrance.com/Music-Events-in-London.php>

I am objecting on the grounds that the proposed license does not adhere to

- the prevention of crime and disorder
- public safety
- the prevention of public nuisance
- the protection of children from harm

as defined by the Department for Culture, Media and Sport:

My objections are set out as follows

THE PREVENTION OF CRIME AND DISORDER

Trespass – large numbers of people are using both our premises and the rear access beside the railway line to enter the venue. Despite numerous attempts by our security to stop these people entering they still managed to get in. This illegal entering has caused damage to our property.

Our Staff – Our staff found themselves constantly arguing with the above offenders even though they was only trying to their job and in effect help them as our premises would be a health and safety nightmare for a group of intoxicated partygoers. During the first event our staff witnessed an altercation between a group of partygoers

Historic evidence of an events centre on this road has proven to be extremely unpopular and leaves us in dread of what may happen one of our drivers was shot at as two rival gangs clashed at the event. We had a female member of staff harassed by some partygoers and a number of our cars were damaged again when a group from the event argued out on the streets on that occasion only wooden bats were used. At both recent events we have had trouble exiting our premises to the extent were one driver missed a time slot on a contract as he couldn't leave the yard due to the amount of people out on the road.

PUBLIC SAFETY

The partygoers themselves are a matter of public safety due to the large number of people congregating on such a highly industrialized area they have already shown scant disregard for the area they are in by

A using a busy rail line to gain access to the venue they are walking up the side of the line from the park crossing over the line and coming down the bank on our side to access the venue without paying.

B walking in the middle of the road and in front of large HGV's which are in constant use on this road. There are at least five companies within 100 yards of the venue with vehicles over 18 tonne constantly using the roadways one company works for the railway and needs access to and from their depot throughout the night. We are also sometimes called out on emergency night works and if the last two events are anything to go by with both the large number of cars and people out on the roads accessing our yards would be impossible.

C fire hazard to our property and to those at the event. With the large number of people attending and smoking outside cigarettes are being disregarded after use and may not always be fully extinguished some of these are being thrown onto our property and as we are a waste transfer station there are many flammable materials, if there was ever the unfortunate event of a fire I doubt if the emergency services would be able to access adequately as the cars are not parked in a formal or mannerly fashion.

D This venue would be a complete health and safety nightmare for our company and the other companies legitimately using this industrial estate. Large groups of people exiting the premises many of them in an inebriated/enhanced state right at the gates to our premises were our vehicles are arriving and exiting we pride ourselves on our safety record and initiatives but can't possibly be responsible for anything from 500 – 2000 people in an area were such a large number would have to spill onto the roads from the carriageways. leaving debris strewn all over the place. They are a hazard both to our employees and themselves. I am not even sure if the road could hold this volume of people.

E the safety of our staff arriving to work and being harassed by partygoers especially the female staff

PUBLIC NUISANCE

A Noise whilst speaking to my security staff I could clearly hear the music which was extremely loud

B the amount of people spilling out onto the carriageway, the possible altercations which we have experienced in the past and witnessed at the first event.

C the inconsiderate manner in which the cars are parked blocking all access to our premises and those of our neighbors, parking is at a premium already and the council have only recently (last 2 years) added much needed double yellow lines to allow the free passage of large commercial vehicles. The drivers reported cars parked erratically and not in line with the conditions of the road, many cars were also left to be collected the next day which although very sensible extremely annoying if it means we can't access our premises or exit our site. The property in question has limited (4 spaces at best) off street parking facilities.

D Harassment or intimidation of our staff walking to work or trying to exit the premises.

Historic evidence has lead to both events occurring

E the issue with trespass and the damage to our property

F the cleaning up we have to do the next day from litter on our property were cans etc are thrown over the fence and in the road in general

THE PROTECTION OF CHILDREN FROM HARM

A This venue is at the entrance to a park which is used by children if the partygoers are still around in the morning which they were this weekend I most certainly would not want to walk my young children through a group of people that had been partying all night, regardless of their mood.

B the debris from such a venue, drink cans and possibly other items which follow such events left in the park or out on the roads.

I cannot think of anything less in line with the area than a dance venue and simply implore the council to use common sense when looking at this application please consider the impact of this venue on local businesses who are already facing a challenging environment, the impact of noise and nuisance, traffic movements, road safety and access plus parking problems add up to a logistical and environmental nightmare for the companies and people of the area. I also worry if some sort of precedence will be set and similar businesses like ours and the others that work locally will be overlooked for this type business coming into the area

Yours sincerely,

Caroline O'Donovan

This email has been scanned by the Symantec Email Security.cloud service.
For more information please visit <http://www.symanteccloud.com>

This email has been scanned by the Symantec Email Security.cloud service.
For more information please visit <http://www.symanteccloud.com>

This email and any files transmitted with it are confidential, may be subject to legal privilege and are intended only for the person(s) or organisation(s) to whom this email is addressed. Any unauthorised use, retention, distribution, copying or disclosure is strictly prohibited. If you have received this email in error, please notify the system administrator at Haringey Council immediately and delete this e-mail from your system. Although this e-mail and any attachments are believed to be free of any virus or other defect which might affect any computer or system into which they are received and opened, it is the responsibility of the recipient to ensure they are virus free and no responsibility is accepted for any loss or damage from receipt or use thereof. All communications sent to or from external third party organisations may be subject to recording and/or monitoring in accordance with relevant legislation.

This email has been scanned by the Symantec Email Security.cloud service.
For more information please visit <http://www.symanteccloud.com>

This email has been scanned by the Symantec Email Security.cloud service.
For more information please visit <http://www.symanteccloud.com>

This email has been scanned by the Symantec Email Security.cloud service.
For more information please visit <http://www.symanteccloud.com>

This email has been scanned by the Symantec Email Security.cloud service.
For more information please visit <http://www.symanteccloud.com>

Anderson Chanel

From: Barrett Daliah
Sent: 02 October 2012 07:14
To: Anderson Chanel
Subject: Fw: FW: New Premises Application - Markfield Arts Ltd, 100-108 Markfield Road, Tottenham, London N15 4QF (WK/228428)

From: Chris Coekin [mailto:ccoekin@globalnet.co.uk]
Sent: Tuesday, October 02, 2012 01:01 AM
To: Barrett Daliah
Subject: Re: FW: New Premises Application - Markfield Arts Ltd, 100-108 Markfield Road, Tottenham, London N15 4QF (WK/228428)

To Haringey Premise Licence department

I would like to object to the re submitted application made by Markfield Arts Ltd with regards to the premises at 100 - 108 Markfield Road, Tottenham, London N15 4QF.

As a local resident who lives very close to the proposed venue I oppose these revised plans. This area is quiet and the people here are attempting to build a nice neighbourhood and form a good community spirit, particularly after the recent problems of last summer and the chaos caused down the road at Tottenham retail park. The proposed times for opening and providing live music, dancing and recorded music during the week are bad enough but to propose the times over the weekend are quite frankly outrageous! Friday from 21.00 till 07.00, Saturday from 21.00 till 10.00 and Sunday from 12.00 through to 03.00 is ridiculous. As I say this is a quiet area and there is no doubt that the noise will be heard late at night and in the early hours of the following morning. The capacity at 930 is ludicrous, the disruption caused by the club attendees will have a dramatic negative input on the area. The majority of these I propose will have to get to the premises via Stamford Road after leaving the Seven Sisters tube and then of course they will have to return in the early hours, this will no doubt be after many have consumed alcohol probably lowering their inhibitions and not realising that they are actually in a residential area. The parking situation will also be unworkable as there is limited parking on Markfield road, therefore no doubt people will start to park right outside homes on Stamford Road and surrounding roads thus causing noise throughout the night and early hours as people arrive and leave. Smoking will have to take place outside therefore the noise will not be insulated and voices will carry in the night. Discarded rubbish and litter will also be a major problem, this cannot be dealt with by security staffing of 1/100.

This plan totally neglects or takes into consideration the local community many of whom are children and babies. Personally I have 3 children who attend primary school, they will be woken at night and the music and coming and going of club attendees will have an adverse affect upon their well being, safety and education. Please refer to my earlier objection below to the license proposals, nothing as changed with the details and in fact only recently I and my neighbours have had to contact the noise team at Haringey due to late night parties occurring in the area and the disruption caused.

It feels that if the licence is granted then it is basically giving the local residents a slap in the face and Haringey council saying that they do not care about the well being and standard of life. For too long this area has been run down and neglected, as I said earlier residents around here are attempting to build a good environment for themselves and their families, which has been

difficult and a struggle so to approve this application would only compound our problems and only benefit non residents and have a major negative impact upon health and safety, the environment and crime and disorder.

Dear Sir/Madam

I am writing to you with regards to a proposal for an application for a premise license submitted by Markfield Arts at 100 - 108 Markfield Road, N15. I would like to object and oppose the granting of the license. I am a local resident, I live at 73 Stamford Road, N15 4PH. My house is in very close proximity to the location. I would like to oppose the license on various grounds partly based upon recent experiences of all night events that have taken place in the area.

Public nuisance is a big concern as clubbers walk past my house to get to and from public transport including Seven Sisters tube. Potentially this means that scores of people will be walking right by my front window throughout the night as the events are scheduled to be running throughout the night until day break the following morning. Potentially many people will have been drinking alcohol resulting in drunkenness. My previous experiences have seen physical fights, shouting, urinating and smashing of bottles on Stamford Road. I have had people climbing in my trees, jumping on my fence and throwing empty bottles in my garden and banging on my door. This is no fun when it is happening in the early hours of the morning. To turn the application down will result in the prevention of crime and disorder and maintain public safety.

I also have three children, two 3 year olds and one 8 year old. Any disturbance or noise will wake them up, they become scared and apprehensive and are deprived of sleep. The sound from the trance raves will certainly be heard in my house as this area is not near a main road and is generally very quiet, any noise generated from the club will undoubtedly have an affect upon the well being of the children and other householders. Presently there are lots of young children and new born babies who live on Stamford road, people like us who want to live in a quiet environment will potentially have this taken away from us by non residents. Therefore the plans for all night trance raves will potentially be very harmful to children. It just seems a ridiculous proposal and is certainly not in the local area residents best interest.

Yours Faithfully

Chris Coekin

73 Stamford Road
N15 4PH
London

On Oct 1 2012, Barrett Daliah wrote:

Dear Sir

Please ensure that you submit your representation back to us before midnight on 2nd October 2012.

Regards
Daliah Barrett

This email and any files transmitted with it are confidential, may be subject to legal privilege and are intended only for the person(s) or organisation(s) to whom this email is addressed. Any unauthorised use, retention, distribution, copying or disclosure is strictly prohibited. If you have received this email in error, please notify the system administrator at Haringey Council immediately and delete this e-mail from your system. Although this e-mail and any attachments are believed to be free of any virus or other defect which might affect any computer or system into which they are received and opened, it is the responsibility of the recipient to ensure they are virus free and no responsibility is accepted for any loss or damage from receipt or use thereof. All communications sent to or from external third party organisations may be subject to recording and/or monitoring in accordance with relevant legislation.

This email has been scanned by the Symantec Email Security.cloud service.
For more information please visit <http://www.symanteccloud.com>

This email has been scanned by the Symantec Email Security.cloud service.
For more information please visit <http://www.symanteccloud.com>

Anderson Chanel

From: Barrett Daliah
Sent: 27 September 2012 14:23
To: Anderson Chanel
Subject: FW: New Premises Application - Markfield Arts, 100-108 Markfield Road, London N15 4QF
Importance: High

From: PA@odonovan.co.uk [mailto:PA@odonovan.co.uk]
Sent: 27 September 2012 14:09
To: Barrett Daliah
Subject: New Premises Application - Markfield Arts, 100-108 Markfield Road, London N15 4QF
Importance: High

Dear Sirs,

I write to strongly object to the above mentioned application for reasons listed below: -

- The area is in no way suitable for the activities mentioned in the application attached
- There was an illegal venue of a similar nature on Markfield Road a number of years ago that caused disruption not only to the road but the whole area, in particular traces of drugs were evident on the road, continuous fighting and 2 shooting took place
- School children use Markfield Road to go to and from school
- The proposed hours of operation will cause uncontrolled parking issues and obstruct ours and our neighbours normal trading, as it has in the past. These hours will also disrupt the public from freely accessing the park, which is used not only as a place of leisure but as a cut through
- The area is not suitable for a large number of people congregating in the area
- The proposed site is surrounded by a Construction Operation which is not suitable next to a venue of this type and security will be an issue at the surrounding site as we have big construction equipment
- Our Licence allows us to operate from 7am, 6 days a week, we have large Heavy Goods Vehicles running alongside the proposed venue, the element of danger and risk would be escalated to a level beyond control
- Litter and fly tipping will increase dramatically
- Inevitably we would be disturbed by the noise from the proposed venue and by people leaving the site
- Our staff will feel threatened

I am not sure if you are aware but so far in the last month or so at least 2 illegal raves have taken place which caused disruption and a vast increase in debris on the road.

I do hope the council will take my objection seriously and put a stop to this application.

Kind Regards

27/09/2012

Jacqueline O'Donovan
Managing Director
O'Donovan Waste Disposal Limited
Tel: 020 8801 9561
Fax: 020 8808 1043
www.odonovan.co.uk



This email has been scanned by the Symantec Email Security.cloud service.
For more information please visit <http://www.symanteccloud.com>

This email has been scanned by the Symantec Email Security.cloud service.
For more information please visit <http://www.symanteccloud.com>

Anderson Chanel

From: Barrett Daliah
Sent: 27 September 2012 14:42
To: Anderson Chanel
Subject: FW: Markfield arts centre

From: transport@odonovan.co.uk [mailto:transport@odonovan.co.uk]
Sent: 27 September 2012 14:32
To: Barrett Daliah
Subject: Markfield arts centre

Hello,

I would like to object to the Markfield arts centre getting a licence. The last time they had a meeting of sorts there, they had a lot of people drunk coming out of there, it is very scary when at 6am I am going into work on a Saturday trying to park and all these people are milling around the street in the middle of the road and all acting very weird. I would be very worried about Crime in the area as I have had my car Vandalised not too long ago. The noise that comes from there is annoying as well, I just want to come to work in a safe environment and not have to worry about these party animals up all night causing trouble to me or any one else. A couple of weeks ago I saw a group of about 20-30 people coming from the park next door with blankets going in to the arts centre, we have lorries coming and going they have no hi-viz jackets on at all and this is very dangerous.

I hope my concerns are noted.

Thanks

Shane Brown
 Transport Manager
 T:020 8801 9561

www.odonovan.co.uk

O'DONOVAN
 WASTE DISPOSAL LTD

NORTH
LONDON



Having
Waste to
Landfill

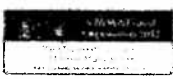

arca **IRSM** Member

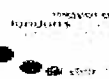

CONTRACTORS

This email and any files transmitted with it are confidential and may be subject to legal privilege and are intended only for the person(s) or organisation(s) to whom this email is addressed. Any unauthorised use, retention, distribution, copying or disclosure is strictly prohibited. If you have received this email in error, please notify the system administrator at O'Donovan Waste Disposal Limited immediately and delete this e-mail from your system. Although this e-mail and any attachments are believed to be free of virus or other defect which might affect any computer or system into which they are received and opened, it is the responsibility of the recipient to ensure they are virus free and no responsibility is accepted for any loss or damage from receipt or use thereof. All communications sent to or from external third party organisations may be subject to recording and/or monitoring in accordance with relevant legislation.

27/09/2012

September 2012

Petition from the residents and businesses in the area surrounding Markfield Road in Tottenham against the application from Markfield Arts Limited at 100-108 Markfield Road, London N15 4QF Tottenham for the following license/premises application:

Provision of Regulated Entertainment: Plays

Wednesday to Thursday 5pm to 2am

Friday to Saturday 5pm to 2am

Sunday to Monday 5pm to 3am

Bank Holidays: to be operating 24 hours

Provision of films:

Monday to Thursday 9am to 12midnight

Bank Holidays: to be operating 24 hours

Provision of Live Music

Wednesday to Thursday 5pm to 2am

Friday to Saturday 6pm to 6.30am

Saturday to Sunday 9pm to 10am

Sunday to Monday 12noon to 3am

Bank Holidays: to be operating 24 hours

Recorded Music, Performances of Dance, Provision of Facilities for Dancing

Wednesday to Thursday 6pm to 2am

Friday to Saturday 6pm to 6.30am

Saturday to Sunday 8pm to 10am

Sunday to Monday 12noon to 3am

Bank Holidays: to be operating 24 hours

Provision of Facilities for Making Music

Monday to Thursday 10am to 12midnight

Bank Holidays: to be operating 24 hours

Provision of Late Night Refreshment

Wednesday to Thursday 11pm to 2am

Friday to Saturday 11pm to 2am

Saturday to Sunday 11pm to 5am

Sunday to Monday 11pm to 3am

Bank Holidays: to be operating 24 hours

Supply of Alcohol

Wednesday to Thursday 5pm to 12midnight

Friday to Saturday 6pm to 7am

Saturday to Sunday 9pm to 10am

Sunday to Monday 12noon to 2.30am

Bank Holidays: to be operating 24 hours

For consumption **ON** the premises

Hours open to the public

Monday to Wednesday 9am to 12midnight

As business owners, residents and members of a thriving local community within the immediate area we feel that this application that is up for consultation has & will continue to be a major disruption. We as a community have grave concerns for general public safety, the health and safety to young children, noise pollution, crime and disorderly behavior along with the use and misuse of drugs and alcohol on the streets within surrounding the area. The safety not only applies to the people who work and live in the area, but also for the people visiting the venue. As there are large industrial businesses that use dangerous machinery, and large vehicles driving up and down the road frequently throughout the week and weekends, both during the day and night.

On the weekend of the 17th of March it was witnessed that the premises held a late night event that had loud music playing throughout the night bringing more people to the area wandering the streets looking for the party. Residents from Fountayne Road said that many strangers wondered straight into their apartment looking for the event that was advertised on the Internet they used the post code of the above address N15 4QF. The noise from the venue during this weekend was also disruptive to a business opposite the event as they work through the night during the week, weekends and over bank holidays.

During the recent Easter weekend there was an event scheduled from 12 noon Sunday 7th to 12 noon Monday 8th April. There was uncompromising levels of loud music played from the venue (A complaint was made to the council reference 6332000). There many people who were in attendance of this event who were witnessed to be drinking outside the licensed domain. This was quite clearly an infringement of the license guidelines. There was little or no control of these constant infringement by the door supervisors who were managing the door.

Also a complaint was made to the police (reference CHS4620 08/04/12). One person even walked into the garage at 61 Markfield Road (opposite the venue) who thought the party was in there because he was so 'drunk' this was at 8pm Sunday 7th April. The venue opened at 12 noon and there where at this time already people visiting the venue drinking on the streets whilst children walked passed with their families to Markfield Park, which is a very busy and popular destination for families during the week, weekends, and bank holidays.

We have been aware of every event that has taken place since the last petition submission due to the disruption it has caused us and other local businesses. There has been substantial vandalism/disruption to the businesses of 61 Markfield Road on the nights of these events. Such as; graffiti on the shutters, people clearly under the influence alcohol and other substances sat in front of 61 Markfield Road on the drive way and pavement, an increased number of people on the street at unsociable hours in the morning making access to our property (which is required 24/7) intimidating and unpleasant. There are times that we have not seen presence of security at the front of Markfield Arts, which does not fill us with much confidence. Vehicles of the attendees of these events are parked on the street in front of the venue and along Markfield Road. Not only is this disruptive to the businesses of Markfield Road but also party goers that seem inebriated have left the said parties and have been witnessed to get in their cars, which is a huge concern for the safety of others.

We have had to take actions since these events have taken place to improve the security and safety of our employees/business. Such as extra locks for our gates/doors, not being able to park our vehicles near our work place in fear of vandalism and theft, reconsider our work schedules, due to the problems stated above and their non-compliance of sound regulations. Again people from the events have tried to walk into the building of 61 Markfield Road in the

middle of the night during the Markfield Arts events whilst business owners of 61 Markfield Road are unloading their valuables/products/equipment from their vehicles.

We have evidence of an attendee from one of the events complaining that the bass was so loud she had to leave the event. Please see figure 1

Markfield Road can give the impression of an industrial dead end road, however it is indeed a very busy thoroughfare linking the local residential areas and Markfield Park, the canal as well as the communal recreational and children's play areas used by many families. Markfield Road is also a school route for infants, Junior & secondary school children walking and cycling. There is an adventure playground for disabled children in the park; Markfield Road is also access route for this.

A See FIG 2

According to the Facebook event that advertises the event, 33,683 people were invited to one of their events. With 970 people that had clicked attending, which is surely above their legal capacity? As seen during the event there only seemed to be one security staff working, this is insufficient security for this amount of people. SIA guidelines state that all door-staff must be SIA trained, ideally wearing high-visibility jackets and advises one door-person per 100 guests. This quite clearly was not the case for this event.

The waste & litter created by the recent Easter event was not satisfactorily cleaned up afterwards & there was found to be many cans & bottles from the event the whole length of Markfield Road.

There was also found to be new graffiti found on the morning of Monday the 8th of April on the shutter of 61 Markfield Road opposite the venue. **New Graffiti has been found since this date.**

"As a community, it is our opinion that the new operators of the said property have not & on recent evidence as stated, will not show any consideration to the immediate residents, business users & local families in respect to the running of their venture. As a group we find it wholly unacceptable to have such an enterprise within this sensitive area".

Petition from the residents and businesses in the area surrounding Markfield Road in Tottenham against the application from Markfield Arts Limited at 100-108 Markfield Road, London N15 4QF Tottenham.







NAME	DOB	ADDRESS	RESIDENT	BUSINESS OWNER/EMPLOYEE	CONCERNS	SIGNATURE
Shane Bawn	25/09/62	ALPHA B5 E4		EMPLOYEE	NOISE, VIOLENCE ETC.	
Milton Wadman		82 MARKFIELD RD N15		BUSINESS OWNER	SAFETY	
James Keighney	18/01/81	82 Markfield Rd N15		Employee	Safety Noise Violence	
SULIAN COLL		82 MARKFIELD RD N15		EMPLOYEE	SAFETY NOISE	
P.O. DONOVAN		82 MARKFIELD RD N15		BUSINESS OWNER	SAFETY	
BRIAN HOSFORD		61 MARKFIELD RD.		EMPLOYEE	NOISE SAFETY	
RUSSELL FOSTER		82 MARKFIELD RD, N15 4QF		EMPLOYEE	NOISE SAFETY	
James Clark		82 Markfield Rd N15		Employer	Noise & Safety	
Pauline	11/11/81	90-92 Markfield Rd N15		Employee		

FIG. 2

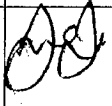
Markfield Arts Ltd

www.facebook.com/pages/Markfield-Arts-ltd/259203007528798

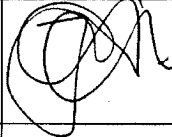
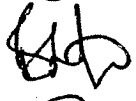
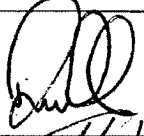
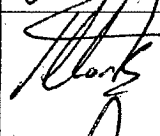
facebook

Search for people, places and things

Markfield Arts Ltd Timeline August



Heidi Ellen Whurr Markfield Arts Ltd August 27

The music was so insanely loud at this event, especially the bass. I couldn't enjoy it at all. The music is the most important part of these events and if you can't even hear it because the bass is too loud how can you ever enjoy it? I left early because of this, its such a shame as yo made such an effort. Had the potential to be an excellent night but was sadly ruined. I hope you learn from this and correct it in future parties.

Like Comment



Andy Forse August 3

Busy busy Busy! More bookings always welcome though ;)

Myopia - August 11th @ Club 414

Shattered Barriers Bank hol. August 26th @Markfield Arts (Feat Avalon, Aphid Moon, Dejavooc...)



Markfield Arts Ltd August 18

Performs 26th August At Markfield Arts https://www.facebook.com/pages/The-FaeDallies/290359577670467



The FaeDallies

The FaeDallies are A splendid collaboration of dancers and performers. With costumes and numerous secret child and thrills to make an event experience a lot more adventurous and full of life. The FaeDallies are switched on beings who will help you step off all your fears and fool free. You can ex... Page: 215 like this

Like Comment Share



Lee Nicholas Markfield Arts Ltd August 3

Nice art work bru, how you doing outthere must be bloody hot, lucky bastard see you soon mate

+ Create A Page

August

Markfield Arts Ltd

Sponsored Visit Estonia



want to enjoy great food & wine in Estonia? Click here and WIN a trip for 2 to Estonia!

Victoria Fedak likes this.

FIG. 2



Chrome File Edit View History Bookmarks Window Help

www.facebook.com/events/392718837452517/

SHATTERED BARRIERS

SHATTERED BARRIERS ***SUNDAY THROUGH MONDAY 24HRS BANK HOLIDAY EVENT***

Public Event · by Abhi Trance and Abhi Trance

Sunday, August 26, 2012 12:00pm

SHATTERED BARRIERS PRESENTS

▶ 24HRS ◀ ||

SUNDAY THROUGH MONDAY BANK HOLIDAY EVENT

...See More

Markfield Arts Ltd
100-108 markfield road, N154QJ London, Unit...

View Map · Get Directions

Abhi Trance
SHATTERED BARRIERS
Presents
TRIBAL VISION V/S IBOGA LABEL PARTY IN LONDON
(Psytrance/Progressive Trance/Prog-Tech/Minimal/Down-tempo/)

View Declines (13 unread)

Invited (33,683)

Maybe (740)

Going (918)

Dan De Roy
Lucy Elizabeth Holland
Rachel González Blanco
Nick Jennings

Export · Report

Events Photo Maybe

Sponsored \$1 Create an Ad

SPRAWL - Adre, July and DearEarth
YES! A new monthly music and art night in Peckham! First night Thursday 27th September.

Join - 88 people are going.

hungryhouse.co.uk
FL Jager-bombs get the best of you! Last night? Order takeaway online @ hungryhouse.co.uk

Like - 47,770 people like this.

70% off Designer Handbags
UK website: thecollective.com
600+ Brands, Up To 70% Off, World's largest vintage fashion marketplace. Join Now!

Paul van Dyk - Evolution World...
Wednesday 17 October / Melkweg Amsterdam / ADE

Join - 202 people are going

Al Voto Italian Restaurant
Pizza + Aperitivo + Brick Lane WIN!

Shah Noshaba

From: Barrett Daliah on behalf of Licensing
Sent: 17 September 2012 12:05
To: Shah Noshaba
Subject: FW: Objection to Markfield Arts Ltd application in Markfield Road

From: laurence.glazier@gmail.com [mailto:laurence.glazier@gmail.com] **On Behalf Of** Laurence Glazier
Sent: 17 September 2012 11:54
To: Licensing
Subject: Objection to Markfield Arts Ltd application in Markfield Road

Dear Licensing Team

I would like to object to the above planning application, whose closing date for objections is 2 October 2012.

I work in Euroart Studios, Markfield Road, which is in a zone where the council is empowered to stop unreasonable noise through noise abatement procedures. Over the past year such action has been taken with respect to noisy churches.

I myself am a composer of classical music, and require a quiet environment in which to work. I work with headphones to ensure no-one else is disturbed. The applicant is in the business of creating noisy events of trance music (see the applicant's website www.abhitrance.com, which says the objective is to create "grand parties" around trance music).

Were this application to be approved, I would have to transfer my work to a quieter area.

I hope you will make the appropriate decision to preserve the peace of this area.

Yours sincerely

Laurence Glazier
Studio 6
Euroart Studios
Unit 5 - Gaunson House
Markfield Road, Tottenham, London, N15 4QQ

laurence@laurenceglazier.com

For future events and online CD click [here](#)

This email has been scanned by the Symantec Email Security.cloud service.
For more information please visit <http://www.symanteccloud.com>

Shah Noshaba

From: Barrett Daliah on behalf of Licensing
Sent: 17 September 2012 10:57
To: Shah Noshaba
Subject: FW: Rave club markfield road n15 Objection

-----Original Message-----

From: Helen Winder [mailto:hiwinder2002@yahoo.com]
Sent: 17 September 2012 10:54
To: Licensing
Subject: Rave club markfield road n15 Objection

Dear Sir/Madam

I am concerned regarding the possibility of a rave club in Markfield Road.

The road is approx half residential and half business. I rent a studio for my business on this road and work flexible times around childcare. I need to feel safe entering and leaving this area, I do not want to come across intoxicated, etc ravers. Also, Broad Lane is very dangerous to cross as it is, I dread to think of people leaving the club drunk trying to cross the road, it is a race course. I want to raise concerns for the residents, already living in small blocks of flats with road noise, many have young children and babies, it wouldnt be fair for them to put up with rave music all night too, not acceptable living conditions.

Also, markfield park at the end of the road is a crucial place for young families to enjoy. The club would encourage drug use and loiterers around this rare green space which Harringay council has spent regenerating into a safe area.

Keep Markfield road green and safe please.

Regards

Helen winder
Euroart
Gaunson house
Markfield road
N15

This email has been scanned by the Symantec Email Security.cloud service.
For more information please visit <http://www.symanteccloud.com>

Shah Noshaba

From: Barrett Daliah on behalf of Licensing
Sent: 17 September 2012 10:57
To: Shah Noshaba
Subject: FW: Markfield arts - planning objection

-----Original Message-----

From: Nigel patrick booth [mailto:nigel.booth@virgin.net]
Sent: 17 September 2012 10:34
To: Licensing
Subject: Markfield arts - planning objection

Dear sir/madame,

I would like to voice my objection regarding the application by MARKFIELD ARTS for it's plans for a club/venue.

This would potentially bring crime, disorder and anti social behavior to the area, threatening the security and peace of the surrounding homes, businesses and workshops.

My company is within the EUROART complex, and we currently enjoy a relatively safe and clean working environment and street to conduct our business. This potentially could change if a club/venue were to open in such an area.

Regards

N. BOOTH - EUROART STUDIOS / MARKFIELD RD

This email has been scanned by the Symantec Email Security.cloud service.
For more information please visit <http://www.symanteccloud.com>

Anderson Chanel

From: Barrett Daliah
Sent: 13 September 2012 15:28
To: Anderson Chanel
Subject: FW: Application for rave nightclub on Markfield Road

-----Original Message-----

From: Cllr Watson Richard
Sent: 13 September 2012 15:21
To: Barrett Daliah
Cc: Cllr Vanier Bernice; Cllr Diakides Isidoros; Cllr Goldberg Joe; Cllr Basu Dhiren; Cllr Basu Dhiren; Cllr Kober Claire (Leader of the Council); Cllr Reith Lorna; Cllr Peacock Sheila
Subject: RE: Application for rave nightclub on Markfield Road

Dear Daliah

Please take this email as my formal objection to the licencing application that has been submitted by Markfield Arts Ltd for a licence for 100-108 Markfield Road, N15 4QF. The application is essence is to create a night club that will offer the sale of alcohol at the following times:

Supply of Alcohol:

Wednesday to Thursday	1700 to 0000 hours
Friday to Saturday	1800 to 0700 hours
Saturday to Sunday	2100 to 1000 hours
Sunday to Monday	1200 to 0230 hours

Bank Holidays: to be operating 24 hours.

Recorded Music, Performances of Dance, Provision of Facilities for Dancing:

Wednesday to Thursday	1800 to 0200 hours
Friday to Saturday	1800 to 0630 hours
Saturday to Sunday	2000 to 1000 hours
Sunday to Monday	1200 to 0300 hours

Bank Holidays: to be operating 24 hours.

Times open to the public:

Monday to Tuesday	0900 to 0000 hours
Wednesday to Friday	0900 to 0200 hours
Friday to Saturday	1800 to 0700 hours
Saturday to Sunday	2100 to 1000 hours
Sunday to Monday	1200 to 0300 hours

Bank Holidays: to be operating 24 hours.

The provision of a night club specialising in dance/trance music opening through to 7 am Saturday morning and until 10am the Sunday morning is hugely detrimental for the local population. Coupled with their proposal to operate for 24 hours across bank holidays is frightening for residents who would wish to enjoy peace and quiet in their home over a bank holiday. There are many businesses and residents living in the vicinity including many on Fountayne Road which backs onto the proposed site. The noise coming from such a place for starters will cause a huge nuisance for people. In addition the volume of people descending from all over London and beyond for such a premises will be a huge nuisance in terms of traffic, parking and people who may have been drinking throughout the night up to 6.30 am or 10am causing a nuisance.

I have concerns in terms of public safety with what would likely be hundreds of people leaving this place throughout the early mornings throughout the week and all weekend leaving a venue likely to have

been drinking up until 3am exiting along Broad Lane which is a busy throughfare or wandering through a residential area (Stamford Road and Stamford Close). In addition a few properties down is O'Donovan's a waste disposal company for which lorries are travelling up and down this road 7 days a week commencing very early and again risk to the safety of users of this club and O'Donovans with loads of people leaving intoxicated.

I also have concerns in relation to harm to children as this is a main route through to Gladesmore Secondary School and thus many children and young people will be going through when on Monday mornings people are leaving the venue up to 10am many of them highly intoxicated or under the influence of drugs commonly associated with the rave scene.

I understand the premises has made use of temporary event notices in the preceding months and I am aware that a resident has reported seeing people urinating the street outside the venue and the increase in rubbish around the area from the raves. I am also aware that the applicant have been served with a warning letter for noise nuisance from an event held under the temporary event notice.

The recent changes to the Licensing Act 2003 requires the applicants to show within their application what consideration they have given to the local community and the impact of their proposed licensable activity will have on the community. I do not feel that the applicants have considered this matter fully in this regard to this local area and how any potential harm would be minimised.

I know that many local residents and businesses are concerned about this and that is goes before Licencing Cttee to be carefully considered and refused.

I have copied in Ward Cllrs for Seven Sisters and Tottenham Green as this proposed site straddles the two wards.

Best wishes
Richard

Richard Watson
Cabinet Member for Communities
Councillor, Tottenham Green Ward

Anderson Chanel

From: Matty Ross [sleepysouluk@gmail.com]

Sent: 12 September 2012 17:30

To: Licensing

Subject: Markfield Arts

To Whom It Concerns,

I wish to object about the application from Markfield Arts regarding their licensing plans.

I am an filmmaker at EuroArt Studios and feel this application can be nothing but disruptive to the people that live and work in this area.

I feel it would be an appalling decision to let them go forward with their plans. Not only with the troubles that alcohol would bring to the street and park areas (which are lovely and peaceful), it will also be a major disruption to the artists like myself that like to work in a quiet environment. This afterall, is our livelihood. You would be jeopardising careers and businesses letting this go through.

I like to work late at night, similarly to artists here, and I would feel unsafe walking back and locking up with gangs and drunken youths nearby.

The beautiful park next to us would also be littered and more than likely vandalised. This is where people like myself like to walk during breaks and I would hate to see the area spoiled. For people walking back at late at night, this area would not be safe.

Thankyou for your time, and I do hope you make a decision that takes all these matters into consideration. I would be absolutely distraught if this application goes through. If you care about the community and the people that forge their careers here, then you must act in a way to protect us.

Yours,

Matty Ross
EuroArt Studios - Unit 4, Studio 41

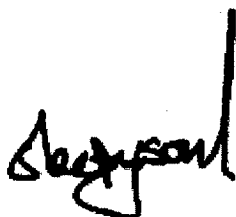

WEB..... <http://www.sleepysoul.com>

EMAIL..... sleepysouluk@gmail.com

MOBILE..... 07745647980

Shah Noshaba

From: Barrett Daliah
Sent: 12 September 2012 00:12
To: Shah Noshaba
Subject: Fw: Markfield Arts Ltd 100-108 Markfield Road, N15 4QF.

From: Cllr Reith Lorna
Sent: Tuesday, September 11, 2012 06:02 PM
To: Licensing
Cc: Barrett Daliah; Cllr Watson Richard
Subject: Markfield Arts Ltd 100-108 Markfield Road, N15 4QF.

Dear Daliah

I wish to make a formal objection to the new licensing application that has been submitted by Markfield Arts Ltd for a licence for 100-108 Markfield Road, N15 4QF. I wish to reiterate the points I made in my previous objection to their last application and the points made by myself and others at the Licensing hearing. There are many businesses and residents living in the vicinity and their representatives made their objections clear at the hearing. I believe that the provision of a night club specialising in dance/trance music opening every night until 2am on mid week nights and all night at weekends is hugely detrimental for the local population.

Although the premises themselves are not in my ward, noise from them does travel, especially at night, and I am concerned about residents in Yarmouth Crescent N17 and Kessock Close N17 who live just the other side of the railway. I myself live in Kessock Close and had to call out the Council's noise team on Saturday 29th July after midnight because of noise from the Markfield Art premises. The Enforcement Duty officer attended my home and confirmed that the noise was excessive. He then visited Markfield Arts premises to ask for the noise to be stopped - this was done. The enforcement officer confirmed to me that a warning letter was then sent to Markfield Arts informing them that a Noise Abatement Notice can be served on them if such noise continues. I understand that Markfield Arts had a TENS for the 29th July. I am concerned that, despite this issue being raised at the licensing hearing and promises made by the applicants that they were sensitive to noise levels and local residents, within a matter of a few weeks their premises were causing noise and nuisance late at night.

In addition the volume of people descending from all over London and beyond for such a premises will be a huge nuisance in terms of traffic, parking and people who may have been drinking throughout the night until the early hours causing a nuisance.

I have concerns in terms of public safety with what would likely to be hundreds of people leaving this place in the early mornings throughout the week and all weekend. They are likely to have been drinking up until 3am and will exit along Broad Lane which is a busy road or will wander through a residential area (Stamford Road and Stamford Close).

I know that many local residents and businesses are concerned about this. I do not believe that this application is substantially different from the previous one submitted by Markfield Arts and I would ask that the Licensing Cttee refuse it.

Thank you.

Councillor Lorna Reith
Tottenham Hale ward (Labour)



DATA PROTECTION: I will treat as confidential any personal information you give me. However, I will allow authorised Council staff to see the information if this is needed to help and advise you and may pass all or some of this information to those council staff if this is necessary to help your case. I may wish to write/email you from time to time to keep you informed about local issues that you may find of interest. Please let me know if you do not wish to be contacted in this way.

Anderson Chanel

From: Barrett Daliah on behalf of Licensing
Sent: 17 September 2012 10:02
To: Anderson Chanel
Subject: FW: Objection to application to start a dance/trance venue in N15 Licence application: Markfield Arts Ltd, 100 - 108 Markfield Road, N15 4QF

-----Original Message-----

From: tessa.rawcliffe@gmail.com [mailto:tessa.rawcliffe@gmail.com] On Behalf Of Tessa Rawcliffe
Sent: 15 September 2012 12:56
To: Licensing
Cc: nayoung@euroart.co.uk
Subject: Fwd: Objection to application to start a dance/trance venue in N15 Licence application: Markfield Arts Ltd, 100 - 108 Markfield Road, N15 4QF

Dear Dahlia

Re-sending my objection.

Tessa

tessa@tessarawcliffe.com

----- Forwarded message -----

From: Tessa Rawcliffe <tessa@tessarawcliffe.com>
Date: 20 August 2012 22:09
Subject: Objection to application to start a dance/trance venue in N15 Licence application: Markfield Arts Ltd, 100 - 108 Markfield Road, N15 4QF
To: licensing@haringey.gov.uk

To: Cllr Watson Richard; Licensing

Cc: Cllr Goldberg Joe; Cllr Diakides Isidoros; Cllr Kober Claire (Leader of the Council); Cllr Peacock Sheila; Cllr Vanier Bernice; Cllr Basu Dhiren
Subject: RE: Application for rave nightclub Markfield Road

From: Cllr Watson Richard
Sent: 15 April 2012 20:04
To: Licensing
Cc: Barrett Daliah; Cllr Goldberg Joe; Cllr Diakides Isidoros; Cllr Kober Claire (Leader of the Council); Cllr Peacock Sheila; Cllr Vanier Bernice; Cllr Basu Dhiren
Subject: Application for rave nightclub Markfield Road

Dear Daliah

Please take this email as my formal objection to the licencing application that has been submitted by Markfield Arts Ltd for a licence for 100-108 Markfield Road, N15 4QF. The application in essence is to create a night club that will operate Wednesday, Friday, Saturday & Sunday.

I agree with the following opinion of Richard Watson, the councillor for the area I work in during the week

and weekend.

Quote: "The provision of a night club specialising in dance/trance music opening every night until 3am on Wednesday, Friday, Saturday & Sunday until 10am the next day at the weekends is hugely detrimental for the local population. There are many businesses and residents living in the vicinity including many on Fountayne Road which backs onto the proposed site. The noise coming from such a place for starters will cause a huge nuisance for people. In addition the volume of people descending from all over London and beyond for such a premises will be a huge nuisance in terms of traffic, parking and people who may have been drinking throughout the night up to 3am causing a nuisance.

I have concerns in terms of public safety with what would likely to be hundreds of people leaving this place throughout the early mornings throughout the week and all weekend leaving a venue likely to have been drinking up until 3am exiting along Broad Lane which is a busy thoroughfare or wandering through a residential area (Stamford Road and Stamford Close). In addition a few properties down is O'Donovan's a waste disposal company for which lorries are travelling up and down this road 7 days a week commencing very early and again risk to the safety of users of this club and O'Donovan's with loads of people leaving intoxicated.

I also have concerns in relation to harm to children as this is a main route through to Gladesmore Secondary School and thus many children and young people will be going through when on Monday mornings people are leaving the venue up to 10am many of them highly intoxicated.

I know that many local residents and businesses are concerned about this and that it goes before Licencing Committee to be carefully considered and refused.

I have copied in Ward Cllrs for Seven Sisters and Tottenham Green as this proposed site straddles the two wards."

I wish to add to Richard Watson's opinion - I am concerned that this venue may create the environment that encourages a drug culture and the ensuing crime culture into the area. I am concerned that my work will be affected by the noise. I am concerned for my own safety, walking about the area as a single female with people walking to and from the club possibly intoxicated by drink or under the influence of drugs.

Regards,

Tessa Rawcliffe
Artist, Studio 6, Unit 5, Gaunson House, Markfield Road, N15 4QQ

tessa@tessarawcliffe.com

This email has been scanned by the Symantec Email Security.cloud service.
For more information please visit <http://www.symanteccloud.com>

LICENCING ACT 2003 – REPRESENTATION FORM

Personal Details:

Name: Nigel Young

Address: Euroart Studios, Unit 4, 5 & 6 Gaunson House
Markfield Road, Tottenham

Postcode: N15 4QQ

Licence application you wish to make a representation on

Application Number: Not known.

Name of Licensee: Markfield Arts Ltd

Premises Address (Where the Licence will take effect):

100 – 108 Markfield Road

Postcode: N15 4QF

Reasons for representation

The Prevention of Crime and Disorder:

- The premises are situated at the end of Markfield Road by the entrance to Markfield Park. There is an amount of space & dead-end alleyways next to it and it is not very well lit at nighttime. The area of park just inside this entrance is the most secluded area in the park, which in past)I understand) was a problem area until large amounts of money was spent to regenerate the park. This entrance is not gated.

It is believed a venue of this nature will be a magnet attracting elements of crime and disorder, including, drugs dealing and prostitution.

- There is limited car parking space in the area, which will lead to disruption, congestion and chaos for local residents (of Markfield Road, Constable Crescent and adjoining roads), and local businesses - as well the 80 creative businesses hosted at Euroart Studios who have 24-hour access to their businesses. Apart from double/triple parking, visitors to the venue will inevitably park their vehicles on the private parking areas of local businesses e.g. Gaunson House and Rainbow Works, which will be sure to cause conflicts and disorder, and I fear, even physical harm, as lots of alcohol will be involved.

Public Safety

- The Markfield Road entrance to Markfield Park is used 24/7 by many people to enjoy the amenities of the park, including many families with young children and the 80 creative practitioners of Euroart. This venue will attract groups of youths whose presence will cause intimidation and make access to the park through the Markfield Road entrance quite impossible for many.
- The "restricted & dead-end areas" around the venue will create a potential danger for women and vulnerable individuals seeking to pass by to/from the park.

- Access to secluded "restricted & dead-end areas around the venue, and secluded area in the park" has the propensity to encourage anti-social behaviour – which will be offensive to the general public given the 24-hours operation being applied for, as well as the proliferation of used syringes & condoms, broken bottles, etc, presenting serious danger to public safety.

The Prevention of Public Nuisance

- Markfield Road is located in the South Tottenham Defined Employment Area (DEA) in the adopted UDP (2006). The preferred uses within this employment area are research and development, light and general industrial and warehousing B1 (b) and (c), B2 and B8. The application is clearly for a "night club" notwithstanding its guise as an "Arts Centre". There are no "artistic provisions" mentioned in the application, only music, dancing and selling of alcohol.

Gaunson House is just 50 yards from the application premises. Euroart's 80 creative practitioners (and also many more in the area) currently enjoy a 24/7 meditative tranquil environment to carry out their businesses. This environment will clearly be destroyed by granting of the Licence, which will bring with it associated public nuisances of extremely loud music & noise, gangs in streets, vomit, broken glass, etc. 80 (maybe more) creative businesses are at risk due to nuisance from such a venue.

It is worth mentioning that the council only last year took measures to effect closure of a number of other "entertainment & religious" venues on Markfield Road due the extreme public nuisance caused.

- It should also be reminded that a great deal of money was recently spent regenerating Markfield Park and restoring the Victorian Beam Engine Museum for public enjoyment. This venue has the propensity to create great public nuisance and deprive many of the enjoyment of the park.

The Protection of Children from Harm

- The applied for opening hours coincide with the opening hours of "The Markfield Project" taking place in the building a short distance from the park entrance. The Markfield Project delivers services to disadvantaged and vulnerable children, most of whom access the building through the Markfield Road entrance.
- There is a large school situated on the edge of the park. Many of the school children pass to & from school via Markfield Road. The children also use this entrance out of school hours to enjoy the various amenities of the park. The children will clearly be at risk, especially at weekends – rowdiness, drunkenness, intimidation, harassment, drugs dealing and other anti-social behaviour.
- The park has a number of amenities used by many children – skateboard park, playing fields, play-park area with swings, etc. All children are clearly at risk.

I, NIGEL YOUNG hereby declare that all information I have submitted is true and correct.

Signed:

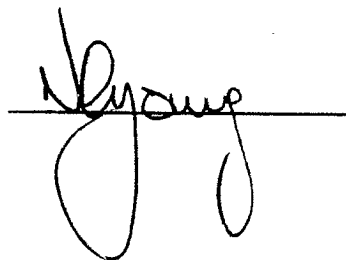

Date:

21 August 2012.

This page is intentionally left blank

APPENDIX 7A – ADDITIONAL REPRESENTATIONS

Anderson Chanel

From: natascha franklin [nataschafranklin@hotmail.co.uk]
Sent: 02 October 2012 17:16
To: Licensing
Subject: Licensing Application 100-108 Markfield Road

Dear Madam/Sir

I am writing to you to strongly object to the application by Markfield Arts Ltd for the proposed use of 100-108 Markfield Road, London, N15 4QF. I live in one of the streets close to Markfield Road. I have already noticed the effect that the events so far have had on my neighbourhood.

We are routinely woken during the night when an event is being staged with "club goers" noisily & well-lubricatedly (!) making their way from the tube or bus stop to the venue and then in the early morning as they start to make their way home, even more worse for wear. Some events end at midday so we have club attendees traipsing up our road and the adjacent roads until the early afternoon. We were slightly luckier this Sunday (the morning after an event). Music was still pounding out at 9.45, when I talked to someone outside about the loudness and monotony of the music I was told that this was an early finish; 10.00am!

The previous event I woke up at about 6.00am and could hear a bass beat rumbling in the distance. I got on my bike to explore the source of the noise. It was a club night being held at Markfield Road. Again.

The noise is not the only problem it is also what happens to Markfield Park the Sunday morning of an event (and if the application were approved this would happen every weekend). The exiting club goers often drunk and or wasted hang around the park shouting at each other, playing on the playground equipment so the little kids feel unable to use them and on more than one occasion I've seen a group of clubbers where 1 of their number is so off his face he can't walk and all his mates are round him shouting or laughing at him. And all this taking place in our lovely park that we worked so hard and spent so much lottery money to improve. AND where we have our beautiful historic Beam Engine that on open day attracts visitors from across the country to come and be faced with that spectacle. It makes me feel ashamed. Especially with the opinion some people may have of Tottenham since the riots. It just doesn't look good.

I can see no benefit of this sort of night club to the local community. And let's face it, this is not a company interested in hosting "Art" events **for** the local community or **showcasing** local artistic talent. To date every event has been a club night playing what sounds like a very small repertoire of hard core banging rave tunes with hi-energy repetitive beats. I have not seen many of my neighbours, young or old, black, brown or white, rushing to attend.

I ask that the council refuse this application in its entirety.

Yours faithfully

Natascha Franklin

N15

This email has been scanned by the Symantec Email Security.cloud service.
For more information please visit <http://www.symanteccloud.com>

29/10/2012

Anderson Chanel

From: Anne Teahan [anne.teahan1@btopenworld.com]
Sent: 31 August 2012 10:42
To: Anne Teahan; Licensing
Cc: Cllr Peacock Sheila
Subject: Resending: OBJECTION TO LICENCING APPLICATION FOR MARKFILED ARTS LTD. N15

I am resending my objection as I made an error in the previous objection in the first sentence. ('4Days' rather than '24 Hours'. Please would you accept this corrected objection, below.

Thanks

Anne Teahan

Subject: OBJECTION TO LICENCING APPLICATION FOR MARKFILED ARTS LTD. N15

OBJECTION TO LICENCING APPLICATION FOR MARKFILED ARTS LTD. N15

I am writing to add my strong objection to the proposed application for four days a week entertainments licence at 100 - 108 Markfield Road, London N15 4QF.

I have been away working and on my return I discover the deadline has passed. I am an artist with a studio in Gaunson House, Markfield Road and I was completely unaware that the application had reemerged, so please would you confirm that my objection has been added to all the others.

My objections remain the same as those made to their previous application: -

I am a Haringey resident, a self employed artist and I have a studio in Gaunson House on Markfield Road, along with many other artists and small creative businesses.

I really don't want to work by a nightclub with all the problems of noise and booze which would go with it. In addition the application includes all sorts of other activities, which means round the clock noise and disruption.

Sometimes I have to work late in the evening and I really would not feel safe having to negotiate nightclub drunks when I leave the studio. I also realise that if they succeed in getting a licence for a few days, the next steps will be to keep adding and extending it.

Tottenham has a bad reputation since the riots. I often have guests and family staying from

other parts of Britain and from abroad, who have heard about the riots.

I would like to invite them to see the positive side of the area which would

> include open studio events at

> EuroArt studios and the local park which at the moment has the

> potential to

> be a beautiful community space. I know that if this development goes

> through I will not be able to continue with my studio work and will

> have to find somewhere else, which I would greatly regret.

>

> Please turn down all aspects of the development. There must be so many

> better ways of using the space and improving the area.

>

> Please mail me confirmation that this email has got through and will
> be included with the objections.

>
> Many thanks

>
> Anne Teahan
> Unit 5
> Euroart Studios
> Gaunson House
> Markfield Road
> London
> N15 4QQ

>
>

This email has been scanned by the Symantec Email Security.cloud service.
For more information please visit <http://www.symanteccloud.com>

Anderson Chanel

From: Fatima Jamadar [fatimajamadar@googlemail.com]
Sent: 21 August 2012 10:55
To: Licensing
Subject: Objection to Licence application: Markfield Arts Ltd, 100 - 108 Markfield Road, N15 4QF

Dear Sir/Madam,

Please take this email as my formal objection to the licencing application that has been submitted by Markfield Arts Ltd for a licence for 100-108 Markfield Road, N15 4QF. The initial application was to create a night club 3am Mon-Thurs, 8pm-10am Saturday and 12pm-10am Sunday. And I understand they are now going for Wed, Friday, Sat & Sunday.

I feel this is detrimental to the local population. We have businesses and residents living in the vicinity including children and is a main route to Gladesmore Secondary School exposing both children, people who live locally, have businesses or travel to the area for work (I travel from Newington Green to my work studio 6 days a week) to loud and highly intoxicated customers from Markfield Arts .

The noise will be huge nuisance for people. The number of people descending from all over London and beyond for such a premises will be a huge nuisance in terms of traffic, parking and people who may have been drinking throughout the night causing a nuisance, public safety with what would likely to be hundreds leaving this place throughout the early mornings drinking up until late and exiting along Broad Lane which is a busy thoroughfare or wandering through a residential area (Stamford Road/Close). In addition few properties down is O'Donocan's a waste disposal company for which lorries are travelling up and down this road 7 days a week commencing very early and again risk to the safety of users of this club and O'Donovans with loads of people leaving intoxicated.

I am a self employed designer- a female who works early mornings and sometimes over night at the art studio and would be highly uncomfortable leaving too late if Markfield Arts were allowed to go ahead. My personal safety and being able to enjoy the area we work in would be hugely affected by such unwelcome businesses that promote & allow customers to be intoxicated, rude and generally unpleasant be it on wed, Fri or the weekend. If anything we need better infrastructure, businesses that bring the community at large together & support each other. It is bad enough to be maligned & prejudiced by having a business in seven sisters but this will make it highly uncomfortable to have my clients visit my studios when we work on deadline/late night projects. It would be noisy & unprofessional and won't feel safe anymore.

To summarise:

- Noise/Nuisance
- Drunk & disorderly
- Safety for local residents/children & business from people spilling out of Markfield Arts
- Safety of Markfield Arts customers who will be spilling onto busy roads with heavy lorries & tankers as they leave intoxicated
- Alcohol consumption outside of the venue
- Increased traffic & lack of parking etc

I would really appreciate it if Haringey council would try and improve the area by not allowing such establishments to be present but by supporting & improving businesses & locals peoples interests.

thanking you in advance,
Fatima Jamadar

This email has been scanned by the Symantec Email Security.cloud service.
For more information please visit <http://www.symanteccloud.com>

Anderson Chanel

From: Johnxbird@aol.com
Sent: 20 August 2012 23:57
To: Licensing
Subject: Markfield Arts Application.

Dear Sirs,

I am an artist practicing my profession at Gaunson House on Markfield Road where I rent a studio from Euroarts Ltd.

I noted your publication for an "Arts Club" in Markfield Road under the name of Markfields Arts. This appears to be nothing other than an application for an all night club drinking club purporting to be an artistic club. I am very concerned about this as I have had previous experience of the opening of such premises in the area where I previously had a studio in Tower Hamlets which completely ruined the nature of the area, caused considerable disruption to the practice of fine art and in time gave rise to problems with the local authority.

In the light of this I would like to register my opposition to this application on the grounds that it will potentially cause problems of Crime and Disorder, it will endanger Public Safety, and also has the potential to create a Public Nuisance

Yours sincerely,

John Bird

John Bird Artist

Website www.johnbird.ws

Studio 23, Unit 5 Gaunston House, Markfield Road, London N15 4QQ.

This email has been scanned by the Symantec Email Security.cloud service.
For more information please visit <http://www.symanteccloud.com>

Anderson Chanel

From: Sasha Andrews [sculler1@yahoo.co.uk]

Sent: 20 August 2012 19:38

To: Licensing

Subject: Licence application: Markfield Arts Ltd, 100 - 108 Markfield Road, N15 4QF

Hi,

I am e-mailing to voice my unhappiness at Markfield Arts Ltd application to increase their licensing hours.

I rent a studio at Euroart Studio where I need to work in peace and quiet. I pay for 24hour access

My objections to the application are the noise, mess and the in ebriated people who collect late at night and are frightening to pass on the street which would all increase.

Please keep do not extend the licensing.

Thank you

Sasha Andrews
Euroart Studios
Markfield Road
London
N15 4QQ

This email has been scanned by the Symantec Email Security.cloud service.
For more information please visit <http://www.symanteccloud.com>

**APPENDIX 8 – SUPPORTING DOCUMENTATION FROM APPLICANTS- CV'S BY
ABISHEK BELTHARIA AND PAUL BACON**

ABHISHEK BELTHARIA

47 ,SPRINGFIELD ROAD,THORNTON HEATH
CROYDON-CR78DZ

abhi_beltharia@yahoo.com

Mobile telephone:07896993830 Home telephone:02088018456

PERSONAL SUMMARY

A motivated, adaptable and responsible Professional always seeking for new challenges to upbeat my Professional career by achieving personal goals and objectivity.

During my degree I successfully combined my studies with work and other commitments showing myself to be self-motivated, organised and capable of working under pressure. I have a clear, logical mind with a practical approach to problem solving and a drive to see things through to completion. I enjoy working on my own initiative or in a team. In short, I am reliable, trustworthy, hardworking and eager to learn and have a genuine interest in PR.

My professional career aim is to work within Human Resources, I enjoy the environment and I find the work interesting and satisfying. The opportunity to learn new skills and work on a day-to-day basis help me grow and understand the important factor and surrounding environment we work with. I feel I have learned more than just the theory behind Human resources and PR but also many fundamental skills for my career and life.

I have shown pride in all the work I do, Having said the above most importantly I am always open to learning more and experiencing work environment from other eyes.

AREAS OF EXPERTISE

- Human Resources
- Public Relation
- Understanding Human Behaviour
- Performance measurement
- Project strategy
- Strive for quality in everything I do.
- Marketing
- Scheduling
- Business Administration
- Team development
- Customer Responsiveness
- Revenue growth
- Effective leadership
- Control & Coordination
- Community Awareness & Development

CAREER HISTORY

JOB TITLE: Managing Director

Employers Name: AbhiTrance Events & Promos Pvt ITd

Employment date: Jan 2009 - Present

Duties

- Budgeting
- Regular communication with the authorities &, local community
- Recruiting Professionals for the company
- See all Licensing condition and objectivities are met.
- Seeking out, establishing and maintaining relationships with operational contacts within each client.
- Public Relation
- Artist Management
- Create Sound Management Plan
- Alcohol Management Plan
- ALL Health & Safety Standard are met

LAST JOB TITLE: CEO (CHIEF EXECUTING OFFICER)

Employers name: Sri Venkateshwara Sponge & Power LTD

Employment date Jan 2007-2009

Duties

- Taking corrective action where inadequate performance is suspected
- Recruiting Professional for the company
- Marketing
- Motivating and guiding a team.
- Seeking out, establishing and maintaining relationships with operational contacts within each client.

- Proactively developing and retaining key customer accounts
- Collecting and analyzing data, then using it to plan and manage both projects and systems
- Keeping costs down by focusing on the reduction of leakage

COMPETENCIES

PROFESSIONAL ABILITIES

- Experienced in the management of a field-based team.
- Ability to work closely with and develop relationships with clients.
- Improving and developing the knowledge & skills of others.
- Highly organized with a positive 'can do' attitude.
- Knowledge of progress monitoring and reporting.
- Ability to organize clerical work, administration, control systems and financial resources.
- Experience of using modern business methods in a practical way.
- Knowledge of recruiting, selecting and appraising staff.
- Able to handle communications and corporate affairs.

PERSONAL ABILITIES

- Excellent customer facing skills.
- Disciplined, energetic and results orientated.
- High standards of numeracy and literacy.
- Assertive and confident.
- Self-starter, who can multi-task in a demanding environment.
- Having a analytical approach to problem solving.
- Can create an environment where colleagues and staff can develop and excel.

ACADEMIC

SCHOOL NAME: COL.BROWN CAMBRIDGE SCHOOL

**COLLEGE NAME: JIMS(JAGAN INSTITUTE OF
MANAGEMENT AND STUDIES)**

Study dates: 1987- 2001 (SCHOOL) 1st Division

Study dates: 2001-2005 (College) 1st Division

Graduation Qualification: BBA(Bachelor of Business Administration) &
GDIB(Graduate Diploma in International Business)

School Qualification:

Commerce-90%

Economics – 85%

English – 72%

Accounts-73%

Hindi-69%

UNIVERSITY NAME: MIDDLESEX UNIVERSITY,UK

Study dates 2005-2007

MSC (JOINT MASTER IN HUMAN RESOURCE & LEGAL STUDIES)

REFERENCES

Available on request.

Paul Martin Bacon

13 Cherwell Close Maidenhead Berks SL6 8AY

paul@earh-design.co.uk

07710 088947 01628 781925

Training and qualifications

Studied theatre set design and have worked on many stage productions. These productions have involved many logistic and health and safety challenges from exterior theatre and stage installations to full set build at the National Theatre

Have attended courses in Event Management and Crowd Dynamics at City University London with Penny Lancaster of The Purple Guide. Crowd and public safety management and at the Cabinet Office Emergency planning college, Easingwold, York. Will be attending a course in Public Safety in Complex and Built Environments and a course in Applied Crowd Dynamics also at Easingwold later this year later this year

Currently studying for Nebosh international certificate

Trained fire marshal

Hold hygiene certificate

Experience and past achievements

Have been involved in music and theatre production for over 25 years

Event manager of Offworld Festival 2007/2008, Liddington Warren Farm Swindon, Wiltshire

Event manager and licence holder for Cosmo Festival 2010 Vicarage Farm Winchester

Event manager and license holder for Cosmo Festival 2011/2012 Taunton Racecourse | ,Taunton Somerset

Site Manager. The Royal British Legion's 90th year celebrations. Party on The Hill 2011. Liddington Warren Farm Swindon, Wiltshire

Regular benefit Events on board the Golden Hinde Clink St for The Golden Hinde Trust

Recent experience and deeper understanding of H&S in an enclosed event space have gained from a dozen events at Markfield Arts.

References

OCU Operations Fareham Police Station

Police Sergeant Kevin Stanswood

Police sergeant Mike Dassow

07793234661-0239289903-02392899834

Envioromental Health Officer for Winchester City Council Abigail Toms

01962 848340

Civil Protection Officer Swindon Bourough Council. Phillip Woodward

01793 445500

Olivia Walton Licensing Officer Taunton Deane Borough Council

01823 356343

Taunton Racecourse Bob Young Director -01823 337172

**APPENDIX 9 – COPIES OF LETTERS SENT IN RESPONSE TO REPRESENTATION BY
THE APPLICANTS**

MARKFIELD ARTS LTD

Regd office: suite 17789, lower Ground floor 145-157 St. John street EC1V4PW

DATE: 24TH OCT.2012

Dear Councillor Watson,

I wish to respond to the representation that you have submitted in relation to the granting of a licence for the above venue. Your representation refers to the following concerns, these being:

- Supply of alcohol
- Public safety
- Many local residents and businesses being concerned
- Site suitability
- Traffic ,parking and road safety
- Alcohol and drugs misuse
- Noise
- Litter and fly tipping
- Fear of crime and disorder
- Use of alcohol and drugs
- Risks to children
- Sanitation & Waste management

We are duty bound by mandatory conditions to manage alcohol on site. We also have an alcohol management policy ourselves that prevents alcohol being supplied irresponsibly. It is plainly obvious that if the crime, disorder, anti-social behaviour, intimidation, threat to public safety, violence, noise nuisance or disturbance that you have referred to, had occurred at our previous events, then it is quite clear that local residents would, and should, be opposed to this application en-masse. We would also expect both the Police and the Council's health and safety officers to object to the terms of the proposed licence if this was a real concern. We have worked closely with the Responsible Authorities to promote the licensing objectives and will continue to do so. It is clear that they are satisfied with the arrangements that we have put in place and there are no outstanding representations from these experts. There is no need for anyone in the local community to feel threatened. We will have signage-asking people to leave quietly and responsibly and, SIA security staff will be on duty to manage the area immediately around the venue and to encourage attendees to move on once the venue has closed.

The agreed maximum attendance of 450 will not cause disruption and congestion for residents or Businesses. This attendance is no more than events that have been held by us in the past. The Traffic issues that you have raised have not materialised and have not impacted any business or locals residence and nor will they do so in the future.

With regard to noise, again I must reiterate that the local residence have not been bothered by noise as a result of any of the previous events held by Markfield Arts and I'm sure we would have been informed if the local community had felt the need to have made any complaints to the Council about any nuisance or unreasonable disturbance that they have suffered. The Council's expert in environmental noise is clearly content with the arrangements within the application and has not made any formal representation. A small number of businesses have put in representations but quite frankly only representation received from any local resident in regards to the complaint was from Councillor Reith made regarding noise at a Markfield Arts event held on the 29th July. However, we immediately reduced levels within the venue to mitigate the problem. I hope this demonstrates to you how cooperative and quickly we react should any potential problem be identified. Under the proposed licence, we have in place a noise management strategy to strengthen our policy on prevention of public nuisance. To our knowledge, her complaint was the only one received in relation to noise in Markfield Arts from over a dozen Temporary events held. Since the 29th July event we have held 4 events with no complaints at all. The concerns you have with 24hours events over bank holidays frightening residents has not materialised as we have held two of these event with no issues or complaints from local residence and businesses nor will they do so in the future. This illustrates our control measures which are in place. Our noise management strategy involves monitoring any potential noise from the venue in the surrounding area and managing the sound at source within the venue. You really have no need to be concerned.

You should not be concerned with 'people descending from all over London'. Our previous events have been controlled events and you will be pleased to hear that the attendances under this proposed licence, match those that we have held before i.e. 450. Therefore, there will be no congestion or additional impact on the surrounding area.

With regards to litter, we will have sufficient waste receptacles within the curtilage of the venue and will ensure that our SIA security personnel do not allow people to exit with drinking vessels or food packaging and will encourage attendees to dispose of waste before they leave the site.

As for our events cursing litter and rubbish being left in Markfield Road we put great efforts into this particular task, we like to set a high standard. We clean Markfield Road thoroughly during and after every event in many cases cleaning the rubbish of other businesses and the general public, as we are fully aware that we are likely to be blamed for any rubbish left. If you see Markfield Road on a Monday morning when we have not been holding an event you will notice a stark contrast. We have a waste contract with Haringey Council commercial waste and Recycling.

We were made aware from Haringey Council there was a report of people urinating on the Street at an event in early July, we have changed the sanitary provisions and this problem has been eradicated evidence of this is that we have had no further complaints.

With regard to site suitability, we would argue that the site is perfectly suited to a venue operating in the proposed manner. A great deal of time and effort has gone into selecting an

appropriate venue and location. The location is away from residential properties and the proposed hours of operation would mean that there would be little or no disturbance to local businesses operating in the area.

The part of your representation highlighting that 'heavy goods vehicles', 'big construction equipment' and, a construction operation 'running at the side of the proposed venue will result in an element of danger being escalated to a level beyond control' suggests potential problems associated with businesses. I'm sure this is not the case as Markfield Road does connect with a public highway after all. Health and safety legislation requires us to have transport management systems in place in order to prevent pedestrian – vehicle conflict and the Road Traffic Act and Highway Code apply to all road users. This no doubt is in place for those school children who use Markfield Road that you refer to. We are confident that we comply with these requirements. Therefore, we are not concerned that business operation will have any impact on the safe running of our proposed venue.

You also raised "concern in relation to harm to children". Neither the Police nor the other agencies involved in child protection consider this as the case. All licensable activities take place within the venue with strict age restrictions appropriated to each proposed activity and with SIA licensed staff to ensure that this is enforced with a challenge 21 policy as well as to ensure that the immediate area around the venue are managed.

Everything that you raise in your objection is what you 'believe' might happen if the venue is granted a licence and not what has actually happened. There have been over a dozen events held at this venue and run by the proposed licensee and to date, none of your fears have been realised. Please rest assured that the attendance numbers agreed in this proposed licence are no greater than those that have previously been held under Temporary Event Notices.

Financial Impact:

Markfield arts ltd is newly established business that we intend to invest in it as a business and below is the few impact on the local community:

So far we have invested a substantial amount without even being fully active.

Every TEN event we have had has generated over thirty-employment opportunities. Our local contractors includes Plumber, Electrician, Builders, fire Alarm Technicians & security Staff, all construction materials has been procured from local Builders Merchant, Food and beverages for events are all procured locally. We have a good working relationship with local Taxi hire company's. We paying our monthly business rate regular to the council and have a waste contract with Haringey council.

All the above is a brief example of our business impact to the community which I am sure you realize will increase dramatically once our license is granted

We have no desire to cause you undue concerns and would like to work closely with our Neighbouring businesses and surrounding residence in the area to ensure that good working relationships can prosper.

To summarise:

- Markfield Art's aim is for safe, controlled activities that will have minimal impact on the local community
- Adequate controls and effective tried and tested systems are in place for proactive and effective management
- Competent people are in place to manage the premises

I hope that you are able to feel reassured by this response. Please do not hesitate to contact me if you have any queries or require further information. We would also like the opportunity to discuss this in person. Please feel free to contact P.M. Bacon on 07710 088947 to arrange a meeting.

Yours sincerely

Abhishek Beltharia

07896993830

MARKFIELD ARTS LTD

Regd office: suite 17789, lower Ground floor 145-157 St. John street EC1V4PW

DATE: 24TH OCT.2012

Dear Jacqueline O'Donovan,

I wish to respond to the representation that you have submitted in relation to the granting of a licence for the above venue. Your representation refers to the following concerns, these being:

- Site suitability
- Traffic and road safety
- Parking
- Illegal venue and illegal raves
- Alcohol and drugs misuse
- Fear of crime and violence
- Noise
- Litter and fly tipping

With regard to site suitability, we would argue that the site is perfectly suited to a venue operating in the proposed manner. A great deal of time and effort has gone into selecting an appropriate venue and location. The location is away from residential properties and the proposed hours of operation would mean that there would be little or no disturbance to local businesses operating in the area.

The part of your representation highlighting that 'heavy goods vehicles', 'big construction equipment' and, a construction operation 'running at the side of the proposed venue will result in an element of danger being escalated to a level beyond control' suggests potential problems associated with your business. I'm sure this is not the case as you do connect with a public highway after all. Health and safety legislation requires you to have transport management systems in place in order to prevent pedestrian – vehicle conflict and the Road Traffic Act and Highway Code apply to all road users. This no doubt is in place for those school children who use Markfield Road that you refer to. We are sure you comply with these requirements. Therefore, we are not concerned that your business operation will have any impact on the safe running of our proposed venue.

Nor should you be concerned with any potential parking problems. The agreed maximum attendance of 450 will not cause disruption and congestion for businesses or residents.

The illegal venue and raves that you have referred to in your representation have no relation to this application, the venue or the proposed premises licence holder where, all previous events have, and any future event will be legitimately held under the Licensing Act 2003.

There is no evidence to suggest that this venue will attract crime and disorder. The company has a zero tolerance of any drugs at the premises and has a drugs policy to reinforce this. We also have an alcohol management policy and the proposed licence has mandatory conditions that prevent alcohol being supplied irresponsibly. If the crime, disorder, anti-social behaviour, intimidation, threat to public safety, violence, noise nuisance or disturbance that you have referred to, had occurred, then it is quite clear that local residents would, and should, be opposed to this application en-masse. We would also expect both the Police and

the Council's health and safety officers to object to the terms of the proposed licence if this was a real concern. We have worked closely with the Responsible Authorities to promote the licensing objectives. It is clear that they are satisfied with the arrangements that we have put

in place and there are no outstanding representations from these experts. There is no need for the O'Donovan staff to feel threatened. We will have signage asking people to leave quietly and responsibly and, SIA security staff will be on duty to manage the area immediately around the venue and to encourage attendees to move on once the venue has closed.

We fail to see how the staff at O'Donovan's will be disturbed by noise. The 'construction operation', which they refer to as running, is in itself an inevitably noisy enterprise. With regard to noise, you should not have been bothered by noise as a result of any of the previous events held by Markfield Arts and I'm sure we would have been informed if you had felt the need to have made any complaints to the Council about any nuisance or unreasonable disturbance that you have suffered. The Council's expert in environmental noise is clearly content with the arrangements within the application and has not made any formal representation. However, to reassure you further I can confirm that we have a noise management strategy which involves monitoring any potential noise from the venue in the surrounding area and managing the sound at source within the venue. You really have no need to be concerned.

We also fail to see how the proposed venue will dramatically increase fly tipping. If anything it will discourage such illegal activities as there will be some presence in the area. With regards to litter, we will have sufficient waste receptacles within the curtilage of the venue and will ensure that our SIA security personnel do not allow people to exit with drinking vessels or food packaging and will encourage attendees to dispose of waste before they leave the site.

We have no desire to cause you undue concerns and would like to work closely with you as one of our neighbours to ensure that good working relationships can prosper.

To summarise:

- Markfield Art's aim is for safe, controlled activities that will have minimal impact on the local community
- Adequate controls and effective tried and tested systems are in place for proactive and effective management
- Competent people are in place to manage the premises

I hope that are able to feel reassured by this response. Please do not hesitate to contact me if you have any queries or require further information. We would also like the opportunity to discuss this in person please feel free to contact P.M. Bacon on 07710 088947 to arrange a meeting.

Yours sincerely

Abhishek Beltharia

07896993830

MARKFIELD ARTS LTD

Regd office: suite 17789, lower Ground floor 145-157 St. John street EC1V4PW

DATE: 24TH OCT. 2012

Dear Nigel Young (Euro arts),

I wish to respond to the representation that you have submitted in relation to the granting of a licence for the above venue. Your representation refers to the following concerns, these being:

- Fear of crime and disorder
- Use of alcohol and drugs
- Prostitution
- Car parking
- Noise
- Risks to children

There is no evidence to suggest that this venue will attract crime and disorder, such as drug dealing and prostitution. The company has a zero tolerance of any drugs at the premises and has a drugs policy to reinforce this. The mere suggestion of prostitution being associated with Markfield Arts is beyond comprehension to this organisation and frankly, quite ridiculous. The venue has an alcohol management policy and the proposed licence has mandatory conditions that prevent alcohol being supplied irresponsibly.

If the crime, disorder, anti-social behaviour, intimidation, threat to public safety, violence, noise nuisance or disturbance that you have referred to, had occurred, then it is quite clear that local residents would, and should, be opposed to this application en-masse. We would also expect both the Police and the Council's health and safety officers to object to the terms of the proposed licence if this was a real concern. We have worked closely with the Responsible Authorities to promote the licensing objectives. It is clear that they are satisfied with the arrangements that we have put in place and there are no outstanding representations from these experts.

The agreed maximum attendance of 450 will not cause disruption and congestion for residents. This attendance is no more than events that have been held by us in the past. The double and triple parking issues that you raise have not materialised and have not impacted on your activities and nor will they do so in the future.

With regard to noise, again I must reiterate that you should not have been bothered by noise as a result of any of the previous events held by Markfield Arts and I'm sure we would have been informed if you had felt the need to have made any complaints to the Council about any nuisance or unreasonable disturbance that you have suffered. The Council's expert in

environmental noise is clearly content with the arrangements within the application and has not made any formal representation. However, to reassure you further I can confirm that we have a noise management strategy which involves monitoring any potential noise from the venue in the surrounding area and managing the sound at source within the venue. You really have no need to be concerned.

We feel it is unjust that you elude to Markfield Arts having a negative impact on the surrounding area and in particular, the use of the Park. As a relatively new business in the area, we want nothing else but the positive promotion of the area and its surroundings.

You also write that "all children are clearly at risk", particularly at weekends. Neither the Police nor the other agencies involved in child protection consider this as the case. All licensable activities take place within the venue with strict age restrictions appropriated to each proposed activity and with SIA licensed staff to ensure that this is enforced with a challenge 21 policy as well as to ensure that the immediate area around the venue are managed.

Everything that you raise in your representation is what you 'believe' might happen if the venue is granted a licence and not what has actually happened. There have been over a dozen events held at this venue and run by the proposed licensee and to date, none of your fears have been realised. Please rest assured that the attendance numbers agreed in this proposed licence are no greater than those that have previously been held under Temporary Event Notices.

We have no desire to cause you undue concerns and would like to work closely with you as one of our neighbours to ensure that good working relationships can prosper.

To summarise:

- Markfield Art's aim is for safe, controlled activities that will have minimal impact on the local community
- Adequate controls and effective tried and tested systems are in place for proactive and effective management
- Competent people are in place to manage the premises

I hope that are able to feel reassured by this response. Please do not hesitate to contact me if you have any queries or require further information. We would also like to offer the opportunity to discuss this in person please feel free to contact P M Bacon on 07710 088947 to arrange a meeting.

Yours sincerely

Abhishek Beltharia

07896993830

MARKFIELD ARTS LTD

Regd office: suite 17789, lower Ground floor 145-157 St. John street EC1V4PW

DATE: 24TH OCT.2012

Dear Tessa Rawcliffe,

I wish to respond to the representation that you have submitted in relation to the granting of a licence for the above venue. Your representation refers to the following concerns, these being:

- Fear of crime and disorder
- Public safety
- Use of alcohol and drugs
- Car parking and traffic
- Noise
- Risks to children

There is no evidence to suggest that this venue will attract crime and disorder, such as drug dealing. The company has a zero tolerance of any drugs at the premises and has a drugs policy to reinforce this. The venue has an alcohol management policy and the proposed licence has mandatory conditions that prevent alcohol being supplied irresponsibly.

If the crime, disorder, anti-social behaviour, intimidation, threat to public safety, violence, noise nuisance or disturbance that you have referred to, had occurred, then it is quite clear that local residents would, and should, be opposed to this application en-masse. We would also expect both the Police and the Council's health and safety officers to object to the terms of the proposed licence if this was a real concern. We have worked closely with the Responsible Authorities to promote the licensing objectives. It is clear that they are satisfied with the arrangements that we have put in place and there are no outstanding representations from these experts.

The agreed maximum attendance of 450 will not cause disruption and congestion for residents. This attendance is no more than events that have been held by us in the past. The parking issues that you raise have not materialised and have not impacted on your activities and nor will they do so in the future.

With regard to noise, again I must reiterate that you should not have been bothered by noise as a result of any of the previous events held by Markfield Arts and I'm sure we would have been informed if you had felt the need to have made any complaints to the Council about any nuisance or unreasonable disturbance that you have suffered. The Council's expert in environmental noise is clearly content with the arrangements within the application and has not made any formal representation. However, to reassure you further I can confirm that we have a noise management strategy which involves monitoring any potential noise from the

venue in the surrounding area and managing the sound at source within the venue. You really have no need to be concerned.

We feel it is unjust that you elude to Markfield Arts having a negative impact on the surrounding areas. As a relatively new business in the area, we want nothing else but the positive promotion of the area and its surroundings.

You also write that you were "concerned in relation to harm to children on Monday mornings". We are not open to public on Monday mornings with the possible exception of bank holidays when the schools are closed. Neither the Police nor the other agencies involved in child protection consider our operating times as posing a threat to children. All licensable activities take place within the venue with strict age restrictions appropriated to each proposed activity and with SIA licensed staff to ensure that this is enforced with a challenge 21 policy as well as to ensure that the immediate area around the venue are managed.

Everything that you raise in your representation is what you 'believe' might happen if the venue is granted a licence and not what has actually happened. There have been over a dozen events held at this venue and run by the proposed licensee and to date, none of your fears have been realised. Please rest assured that the attendance numbers agreed in this proposed licence are no greater than those that have previously been held under Temporary Event Notices.

We have no desire to cause you undue concerns for your personal safety and would like to work closely with you as one of our neighbours to ensure that good working relationships can prosper.

To summarise:

- Markfield Art's aim is for safe, controlled activities that will have minimal impact on the local community
- Adequate controls and effective tried and tested systems are in place for proactive and effective management
- Competent people are in place to manage the premises

I hope that you are able to feel reassured by this response. Please do not hesitate to contact me if you have any queries or require further information. We would also like the opportunity to discuss this in person. Please feel free to contact P.M. Bacon on 07710 088947 to arrange a meeting.

Yours sincerely

Abhishek Beltharia

07896993830

MARKFIELD ARTS LTD

Regd office: suite 17789, lower Ground floor 145-157 St. John street EC1V4PW

DATE: 24TH

OCT.2012

Dear Matty Ross,

I wish to respond to the representation that you have submitted in relation to the granting of a license for the above venue. Your representation refers to the following concerns, these being:

- Fear of crime and disorder
- Public safety
- Use of alcohol
- Litter & Vandalism

There is no evidence to suggest that this venue will attract crime and disorder, the venue has an alcohol management policy and the proposed license has mandatory conditions that prevent alcohol being supplied irresponsibly.

If the crime, disorder, anti-social behaviour, intimidation, threat to public safety, violence, noise nuisance or disturbance that you have referred to, had occurred, then it is quite clear that local residents would, and should, be opposed to this application en-masse. We would also expect both the Police and the Council's health and safety officers to object to the terms of the proposed license if this was a real concern. We have worked closely with the Responsible Authorities to promote the licensing objectives. It is clear that they are satisfied with the arrangements that we have put in place and there are no outstanding representations from these experts.

The agreed maximum attendance of 450 will not cause disruption and congestion for residents. This attendance is no more than events that have been held by us in the past.

We feel it is unjust that you elude to Markfield Arts having a negative impact on the surrounding areas. As a relatively new business in the area, we want nothing else but the positive promotion of the area and its surroundings.

You also write "you would feel unsafe walking back and locking up with gangs and drunken youths nearby. Also the beautiful park next to us would also be littered and vandalized"

I am sorry to hear that you are worried about crime, litter and vandalism in the area. I have to say that I am reassured that you have not linked the vandalism of any sort with the Markfield Arts events that have taken place in the past. You shouldn't be concerned about crime in the area as a result of this license application. The Police do not have these concerns and, as a result, have not made a representation.

With regards to litter, we will have sufficient waste receptacles within the curtilage of the venue and will ensure that our SIA security personnel do not allow people to exit with drinking vessels or food packaging and will encourage attendees to dispose of waste before they leave the site.

As for our events cursing litter and rubbish being left in Markfield Road we put great efforts into this particular task, we like to set a high standard. We clean Markfield Road thoroughly during and after every event in many cases cleaning the rubbish of other businesses and the general public, as we are fully aware that we are likely to be blamed for any rubbish left. If you see Markfield Road on a Monday morning when we have not been holding an Event you will notice a stark contrast. Everything that you raise in your representation is what you 'believe' might happen if the

venue is granted a license and not what has actually happened. There have been over a dozen events held at this venue and run by the proposed licensee and to date, none of your fears have been realised. Please rest assured that the attendance numbers agreed in this proposed license are no greater than those that have previously been held under Temporary Event Notices.

We have no desire to cause you undue concerns for your personal safety and would like to work closely with you as one of our neighbours to ensure that good working relationships can prosper.

To summarise:

- Markfield Art's aim is for safe, controlled activities that will have minimal impact on the local community
- Adequate controls and effective tried and tested systems are in place for proactive and effective management
- Competent people are in place to manage the premises

I hope that you are able to feel reassured by this response. Please do not hesitate to contact me if you have any queries or require further information. We would also like the opportunity to discuss this in person. Please feel free to contact P.M. Bacon on 07710 088947 to arrange a meeting.

Yours sincerely

Abhishek Beltharia

07896993830

MARKFIELD ARTS LTD

Regd office: suite 17789, lower Ground floor 145-157 St. John street EC1V4PW

DATE: 24TH OCT.2012

Dear Lorna Reith,

I wish to respond to the representation that you have submitted in relation to the granting of a licence for the above venue. Your representation refers to the following concerns, these being:

- Noise
- Traffic and parking
- Use of alcohol
- Public safety and the fear of crime
- Many local residents and businesses being concerned

The Council's own expert on environmental noise is not concerned with the proposed activities within the licence application. You mention that you know that many businesses and residents living in the vicinity are concerned about the application. A small number of businesses have put in representations but quite frankly yours is the only representation received from any local resident. You also refer to a complaint you made regarding noise at a Markfield Arts event on the 29th July. To our knowledge, your complaint was the only one received, we immediately reduced levels within the venue to mitigate the problem. I hope this demonstrates to you how cooperative and quickly we react should any potential problem be identified. Since the 29th July event we have held 4 events with no complaints at all. Under the proposed licence, we have in place a noise management strategy to strengthen our policy on prevention of public nuisance. Kessock Close at the junction of Yarmouth Crescent is one of our monitoring locations.

You should not be concerned with 'people descending from all over London'. Our previous events have been controlled events and you will be pleased to hear that the attendances under this proposed licence, match those that we have held before. Therefore, there will be no congestion or additional impact on the surrounding area.

We are duty bound by mandatory conditions to manage alcohol on site. We also have an alcohol management policy ourselves that prevents alcohol being supplied irresponsibly. It is plainly obvious that if the crime, disorder, anti-social behaviour, intimidation, threat to public safety, violence, noise nuisance or disturbance that you have referred to, had occurred at our previous events, then it is quite clear that local residents would, and should, be opposed to this application en-masse. We would also expect both the Police and the Council's health and safety officers to object to the terms of the proposed licence if this was a real concern. We have worked closely with the Responsible Authorities to promote the licensing objectives and will continue to do so. It is clear that they are satisfied with the arrangements that we

have put in place and there are no outstanding representations from these experts. There is no need for anyone in the local community to feel threatened. We will have signage asking people to leave quietly and responsibly and, SIA security staff will be on duty to manage the area immediately around the venue and to encourage attendees to move on once the venue has closed.

We have no desire to cause you undue concerns and would like to work closely with you as one of our neighbours to ensure that good working relationships can prosper.

To summarise:

- Markfield Art's aim is for safe, controlled activities that will have minimal impact on the local community
- Adequate controls and effective tried and tested systems are in place for proactive and effective management
- Competent people are in place to manage the premises

I hope that are able to feel reassured by this response. Please do not hesitate to contact me if you have any queries or require further information. We would also like to offer the opportunity to discuss this in person please feel free to contact P M Bacon on 07710 088947 to arrange a meeting.

Yours sincerely

Abhishek Beltharia

07896993830

MARKFIELD ARTS LTD

Regd office: suite 17789, lower Ground floor 145-157 St. John street EC1V4PW

DATE: 24TH OCT.2012

Dear Shane Brown,

I wish to respond to the representation that you have submitted in relation to the granting of a licence for the above venue. Your representation refers to the following concerns, these being:

- Fear of crime and vandalism
- Supply of alcohol
- Noise
- Traffic and road safety

There is no evidence to suggest that this venue will attract crime and disorder. The company has a zero tolerance of any drugs at the premises and has a drugs policy to reinforce this as well as an alcohol management policy. The proposed licence has mandatory conditions that prevent alcohol being supplied irresponsibly. SIA licensed security staff will be onsite to ensure that these policies are adhered to, as well as to maintain order in and around the venue.

I am sorry to hear that you are worried about crime in the area and have had your car vandalised. I have to say that I am reassured that you have not linked the vandalism to your car with the Markfield Arts events that have taken place in the past. You shouldn't be concerned about crime in the area as a result of this licence application. The Police do not have these concerns and, as a result, have not made a representation.

You seem to suggest that people using Markfield Road are in danger from the business operations, presumably your employer's vehicle movements that take place on Markfield Road. We do not feel that our customers, or any other member of the public using Markfield Road, require, or should have to be provided with hi-viz clothing on what is a public highway.

We have no desire to cause you undue concerns and would like to work closely with you and your employer as one of our neighbours to ensure that good working relationships can prosper.

To summarise:

- Markfield Art's aim is for safe, controlled activities that will have minimal impact on the local community
- Adequate controls and effective tried and tested systems are in place for proactive and effective management
- Competent people are in place to manage the premises

I hope that are able to feel reassured by this response. Please do not hesitate to contact me if you have any queries or require further information. We would also like to offer the opportunity to discuss this in person please feel free to contact P M Bacon on 07710 088947 to arrange a meeting.

Yours sincerely

Abhishek Beltharia

07896993830

MARKFIELD ARTS LTD

Regd office: suite 17789, lower Ground floor 145-157 St. John street EC1V4PW

DATE: 26TH

OCT.2012

Dear Nigel Booth,

I wish to respond to the representation that you have submitted in relation to the granting of a licence for the above venue. Your representation refers to the following concerns, these being:

- Fear of crime and disorder
- Anti-Social Behaviour
- Public Safety

There is no evidence to suggest that this venue will attract crime and disorder. The venue has an alcohol management policy and the proposed licence has mandatory conditions that prevent alcohol being supplied irresponsibly.

If the crime, disorder, anti-social behaviour, intimidation, threat to public safety, nuisance or disturbance that you have referred to, had occurred, then it is quite clear that local residents would, and should, be opposed to this application en-masse. We would also expect both the Police and the Council's health and safety officers to object to the terms of the proposed licence if this was a real concern. We have worked closely with the Responsible Authorities to promote the licensing objectives. It is clear that they are satisfied with the arrangements that we have put in place and there are no outstanding representations from these experts. The issues that you raise have not materialised and have not impacted surrounding homes, businesses and workshops and nor will they do so in the future.

The agreed maximum attendance of 450 will not cause disruption and congestion for residents. This attendance is no more than events that have been held by us in the past.

We feel it is unjust that you elude to Markfield Arts having a negative impact on the surrounding area and in particular, the use of the Park. As a relatively new business in the area, we want nothing else but the positive promotion of the area and its surroundings.

Everything that you raise in your representation is what you 'believe' might happen if the venue is granted a licence and not what has actually happened. There have been over a dozen events held at this venue and run by the proposed licensee and to

date, none of your fears have been realised. Please rest assured that the attendance numbers agreed in this proposed licence are no greater than those that have previously been held under Temporary Event Notices.

We have no desire to cause you undue concerns and would like to work closely with you as one of our neighbours to ensure that good working relationships can prosper.

To summarise:

- Markfield Art's aim is for safe, controlled activities that will have minimal impact on the local community
- Adequate controls and effective tried and tested systems are in place for proactive and effective management
- Competent people are in place to manage the premises

I hope that are able to feel reassured by this response. Please do not hesitate to contact me if you have any queries or require further information. We would also like to offer the opportunity to discuss this in person please feel free to contact P M Bacon on 07710 088947 to arrange a meeting.

Yours sincerely

Abhishek Beltharia

07896993830

MARKFIELD ARTS LTD

Regd office: suite 17789, lower Ground floor 145-157 St. John street EC1V4PW.

DATE: 26TH OCT.2012

Dear Helen Winder,

I wish to respond to the representation that you have submitted in relation to the granting of a licence for the above venue. Your representation refers to the following concerns, these being:

- Fear of crime and disorder
- Public safety
- Use of alcohol and drugs
- Road Traffic
- Noise

There is no evidence to suggest that this venue will attract crime and disorder, such as drug dealing. The company has a zero tolerance of any drugs at the premises and has a drugs policy to reinforce this. The venue has an alcohol management policy and the proposed license has mandatory conditions that prevent alcohol being supplied irresponsibly.

If the crime, disorder, intimidation, threat to public safety, nuisance or disturbance that you have referred to, had occurred, then it is quite clear that local residents would, and should, be opposed to this application en-masse. We would also expect both the Police and the Council's health and safety officers to object to the terms of the proposed licence if this was a real concern. We have worked closely with the Responsible Authorities to promote the licensing objectives. It is clear that they are satisfied with the arrangements that we have put in place and there are no outstanding representations from these experts.

The agreed maximum attendance of 450 will not cause disruption and congestion for residents. This attendance is no more than events that have been held by us in the past. "The people leaving the Venue trying to cross the road issue" that you raise have not materialised and have not impacted neighbouring businesses and nor will they do so in the future.

With regard to noise, again I must reiterate that you should not have been bothered by noise as a result of any of the previous events held by Markfield Arts and I'm sure we would have been informed if you had felt the need to have made any complaints

to the Council about any nuisance or unreasonable disturbance that you have suffered. We are in dialogue with the Haringey Council Enforcement Response Team to install a noise-limiting device in the Venue and set a level approved by the response team prior to regulated entertainment taking place in conjunction with the premises license.

However, to reassure you further I can confirm that we have a noise management strategy, which involves monitoring any potential noise from the venue in the surrounding area and managing the sound at source within the venue. You really have no need to be concerned.

We feel it is unjust that you elude to Markfield Arts having a negative impact on the surrounding areas. As a relatively new business in the area, we want nothing else but the positive promotion of the area and its surroundings.

Everything that you raise in your representation is what you 'believe' might happen if the venue is granted a licence and not what has actually happened. There have been over a dozen events held at this venue and run by the proposed licensee and to date, none of your fears have been realised. Please rest assured that the attendance numbers agreed in this proposed licence are no greater than those that have previously been held under Temporary Event Notices.

We have no desire to cause you undue concerns for your personal safety and would like to work closely with you as one of our neighbours to ensure that good working relationships can prosper.

To summarise:

- Markfield Art's aim is for safe, controlled activities that will have minimal impact on the local community
- Adequate controls and effective tried and tested systems are in place for proactive and effective management
- Competent people are in place to manage the premises

I hope that you are able to feel reassured by this response. Please do not hesitate to contact me if you have any queries or require further information. We would also like the opportunity to discuss this in person. Please feel free to contact P.M. Bacon on 07710 088947 to arrange a meeting.

Yours sincerely

Abhishek Beltharia

07896993830

MARKFIELD ARTS LTD

Regd office: suite 17789, lower Ground floor 145-157 St. John street EC1V4PW

DATE: 26TH OCT.2012

Dear Laurence Glazier,

I wish to respond to the representation that you have submitted in relation to the granting of a licence for the above venue. Your representation refers to the following concern. This being:

- Noise

There is no evidence to suggest that this venue will have unreasonable noise. You should not have been bothered by noise as a result of any of the previous events held by Markfield Arts and I'm sure we would have been informed if you had felt the need to have made any complaints to the Council about any nuisance or unreasonable disturbance that you have suffered.

We are in dialogue with the Haringey Council Enforcement Response Team to install a noise-limiting device in the Venue and set a level approved by the response team prior to regulated entertainment taking place in conjunction with the premises license.

We feel it is unjust that you elude to Markfield Arts having a negative impact on the surrounding areas. As a relatively new business in the area, we want nothing else but the positive promotion of the area and its surroundings.

You also write that the "applicant is in the business of creating noisy event" frankly how you can define one music genre being louder than another? All music events from classical, Jazz Electronic all have the potential of being noisy. It simply comes down to control measures, to reassure you further I can confirm that we have a noise management strategy, which involves monitoring any potential noise from the venue in the surrounding area and managing the sound at source within the venue. You really have no need to be concerned.

Everything that you raise in your representation is what you 'believe' might happen if the venue is granted a licence and not what has actually happened. There have been over a dozen events held at this venue and run by the proposed licensee and to date, none of your fears have been realised. Please rest assured that the attendance numbers agreed i.e.450 in this proposed licence are no greater than those that have previously been held under Temporary Event Notices.

We have no desire to cause you undue concerns and would like to work closely with you as one of our neighbours to ensure that good working relationships can prosper.

To summarise:

- Markfield Art's aim is for safe, controlled activities that will have minimal impact on the local community
- Adequate controls and effective tried and tested systems are in place for proactive and effective management
- Competent people are in place to manage the premises

I hope that you are able to feel reassured by this response. Please do not hesitate to contact me if you have any queries or require further information. We would also like the opportunity to discuss this in person. Please feel free to contact P.M. Bacon on 07710 088947 to arrange a meeting.

Yours sincerely

Abhishek Beltharia

07896993830

This page is intentionally left blank

MARKFIELD INTERNATIONAL LIMITED

**110-118 Markfield Road
London N15 4QF**

24th August 2012

TO WHOM IT MAY CONCERN

Dear Sirs

Re: 108 Markfield Road

We have the property 110-118 Markfield Road which is next door to the above premises and are happy to confirm that we have not experienced any problems with the occupiers of the these premises whatsoever.

They appear to run their business in a competent responsible manner and therefore, at this time we cannot find any reason to oppose their application for an Art/Photograhpy Studio and associated events.

We are pleased that these adjoining premises **after some three years of being unoccupied** has now been let to some promising entrepreneurs who are bñnging employment to Haringey.

Yours faithfully,

P.A. Kelly
Director

This page is intentionally left blank

MARKFIELD ARTS LTD

Regd office: suite 17789,lower Ground floor 145-157 St. John street EC1V4PW

DATE: 30TH OCT.2012

Dear Anne Teahan,

I wish to respond to the representation that you have submitted in relation to the granting of a licence for the above venue. Your representation refers to the following concerns, these being:

- Use of Alcohol
- Public Safety
- Noise

We are duty bound by mandatory conditions to manage alcohol on site. We also have an alcohol management policy ourselves that prevents alcohol being supplied irresponsibly. It is plainly obvious that if the crime, disorder, anti-social behaviour, intimidation, threat to public safety, nuisance or disturbance that you have referred to, had occurred at our previous events, then it is quite clear that local residents would, and should, be opposed to this application en-masse. We would also expect both the Police and the Council's health and safety officers to object to the terms of the proposed licence if this was a real concern. We have worked closely with the Responsible Authorities to promote the licensing objectives and will continue to do so. It is clear that they are satisfied with the arrangements that we have put in place and there are no outstanding representations from these experts. There is no need for anyone in the local community to feel threatened. We have signage-asking people to leave quietly and responsibly and, SIA security staff will be on duty to manage the area immediately around the venue and to encourage attendees to move on once the venue has closed. All licensable activities take place within the venue with strict age restrictions appropriated to each proposed activity and with SIA licensed staff to ensure that this is enforced with a challenge 21 policy as well as to ensure that the immediate area around the venue are managed.

With regard to noise, again I must reiterate that you should not have been bothered by noise as a result of any of the previous events held by Markfield Arts and I'm sure we would have been informed if you had felt the need to have made any complaints to the Council about any nuisance or unreasonable disturbance that you have suffered. We are also in dialogue with the Haringey Council Enforcement Response Team to install a noise-limiting device in the Venue and set a level approved by the response team prior to regulated entertainment taking place in conjunction with the premises license.

However, to reassure you further I can confirm that we have a noise management strategy, which involves monitoring any potential noise from the venue in the surrounding area and managing the sound at source within the venue. You really have no need to be concerned.

We feel it is unjust that you elude to Markfield Arts having a negative impact on the surrounding area and in particular, Euro arts and use of the Park. As a relatively new business in the area, we want nothing else but the positive promotion of the area and its surroundings.

Everything that you raise in your representation is what you 'believe' might happen if the venue is granted a licence and not what has actually happened. There have been over a dozen events held at this venue and run by the proposed licensee and to date, none of your fears have been realised. Please rest assured that the attendance numbers agreed in this proposed licence are no greater than those that have previously been held under Temporary Event Notices.

We have no desire to cause you undue concerns and would like to work closely with you as one of our neighbours to ensure that good working relationships can prosper.

To summarise:

- Markfield Art's aim is for safe, controlled activities that will have minimal impact on the local community
- Adequate controls and effective tried and tested systems are in place for proactive and effective management
- Competent people are in place to manage the premises

I hope that you are able to feel reassured by this response. Please do not hesitate to contact me if you have any queries or require further information. We would also like the opportunity to discuss this in person please feel free to contact P M Bacon on 07710 088947 to arrange a meeting.

Yours sincerely

Abhishek Beltharia

07896993830

This page is intentionally left blank

MARKFIELD ARTS LTD

Regd office: suite 17789,lower Ground floor 145-157 St. John street EC1V4PW

DATE: 30TH

OCT.2012

Dear Fatima Jamadar,

I wish to respond to the representation that you have submitted in relation to the granting of a license for the above venue. Your representation refers to the following concerns, these being:

- Safety for local residents/children & business from people spilling out of Markfield Arts
- Safety of Markfield Arts customers who will be spilling onto busy roads with heavy lorries & tankers as they leave intoxicated
- Increased traffic & lack of parking etc
- Drunk & disorder
- Alcohol consumption outside of the venue
- Noise/Nuisance

With regard to site suitability, we would argue that the site is perfectly suited to a venue operating in the proposed manner. A great deal of time and effort has gone into selecting an appropriate venue and location. The location is away from residential properties and the proposed hours of operation would mean that there would be little or no disturbance to local businesses operating in the area.

The part of your representation highlighting that 'heavy Lorries & tankers', a construction operation running at the side of the proposed venue will result in an element of danger. I'm sure this is not the case as they do connect with a public highway after all. Health and safety legislation requires you to have transport management systems in place in order to prevent pedestrian – vehicle conflict and the Road Traffic Act and Highway Code apply to all road users. This no doubt is in place for our premises user and school children or any pedestrian who use Markfield Road. We are sure they comply with these requirements. Therefore, we are not concerned that O'Donovan business operation will have any impact on the safe running of our proposed venue.

You should not be concerned with 'people descending from all over London'. Our previous events have been controlled events and you will be pleased to hear that the attendances under this proposed licence, match those that we have held before. Therefore, there will be no

congestion or additional impact on the surrounding area. Nor should you be concerned with any potential parking problems. The issues that you raise regarding parking have not materialised and have not impacted on your activities and nor will they do so in the future.

The agreed maximum attendance of 450 will not cause disruption and congestion for businesses or residents.

There is no evidence to suggest that this venue will attract crime and disorder. We are duty bound by mandatory conditions to manage alcohol on site. We also have an alcohol management policy ourselves that prevents alcohol being supplied irresponsibly. It is plainly obvious that if the crime, disorder, anti-social behaviour, intimidation, threat to public safety, nuisance or disturbance that you have referred to, had occurred at our previous events, then it is quite clear that local residents would, and should, be opposed to this application en-masse. We would also expect both the Police and the Council's health and safety officers to object to the terms of the proposed licence if this was a real concern. We have worked closely with the Responsible Authorities to promote the licensing objectives and will continue to do so. It is clear that they are satisfied with the arrangements that we have put in place and there are no outstanding representations from these experts. There is no need for anyone in the local community to feel threatened. We will have signage-asking people to leave quietly and responsibly and, SIA security staff will be on duty to manage the area immediately around the venue and to encourage attendees to move on once the venue has closed.

You also write "all children are at risk". Neither the Police nor the other agencies involved in child protection consider this as the case. All licensable activities take place within the venue with strict age restrictions appropriated to each proposed activity and with SIA licensed staff to ensure that this is enforced with a challenge 21 policy as well as to ensure that the immediate area around the venue are managed.

You should not have been bothered by noise as a result of any of the previous events held by Markfield Arts and I'm sure we would have been informed if you had felt the need to have made any complaints to the Council about any nuisance or unreasonable disturbance that you have suffered.

We are in dialogue with the Haringey Council Enforcement Response Team to install a noise-limiting device in the Venue and set a level approved by the response team prior to regulated entertainment taking place in conjunction with the premises license.

We feel it is unjust that you elude to Markfield Arts having a negative impact on the surrounding areas. As a relatively new business in the

area, we want nothing else but the positive promotion of the area and its surroundings.

Everything that you raise in your representation is what you 'believe' might happen if the venue is granted a license and not what has actually happened. There have been over a dozen events held at this venue and run by the proposed licensee and to date, none of your fears have been realised. Please rest assured that the attendance numbers agreed i.e.450 in this proposed licence are no greater than those that have previously been held under Temporary Event Notices.

We have no desire to cause you undue concerns and would like to work closely with you as one of our neighbours to ensure that good working relationships can prosper.

To summarise:

- Markfield Art's aim is for safe, controlled activities that will have minimal impact on the local community
- Adequate controls and effective tried and tested systems are in place for proactive and effective management
- Competent people are in place to manage the premises

I hope that you are able to feel reassured by this response. Please do not hesitate to contact me if you have any queries or require further information. We would also like the opportunity to discuss this in person. Please feel free to contact P.M. Bacon on 07710 088947 to arrange a meeting.

Yours sincerely

Abhishek Beltharia

07896993830

This page is intentionally left blank

MARKFIELD ARTS LTD

Regd office: suite 17789,lower Ground floor 145-157 St. John street EC1V4PW

DATE: 30TH

OCT.2012

Dear John Bird,

I wish to respond to the representation that you have submitted in relation to the granting of a licence for the above venue. Your representation refers to the following concerns, these being:

- Crime and Disorder
- Public Safety
- Public Nuisance

There is no evidence to suggest that this venue will attract crime and disorder, which will ruined the nature of area, cause considerable disruption to the practise of fine art.

If the crime, disorder, Public nuisance, threat to public safety or disturbance that you have referred to, had occurred at our previous events, then it is quite clear that local residents would, and should, be opposed to this application en-masse. We would also expect both the Police and the Council's health and safety officers to object to the terms of the proposed licence if this was a real concern. We have worked closely with the Responsible Authorities to promote the licensing objectives. It is clear that they are satisfied with the arrangements that we have put in place and there are no outstanding representations from these experts.

The agreed maximum attendance of 450 will not cause any nuisance and congestion for residents. This attendance is no more than events that have been held by us in the past.

You also write this application "has the potential to create Public Nuisance" I am sorry to hear that you are worried about public nuisance in the area, I have to say that I am reassured that you have not linked the Public nuisance of any sort with the Markfield Arts events.

You shouldn't be concerned about crime in the area as a result of this license application. The Police do not have these concerns and, as a result, have not made a representation.

Everything that you raise in your representation is what you 'believe' might happen if the venue is granted a licence and not what has actually happened. There have been over a dozen events held at this venue and run by the proposed licensee and to date, none of your fears have been realised. Please rest assured that the attendance numbers agreed in this proposed licence are no greater than those that have previously been held under Temporary Event Notices.

We have no desire to cause you undue concerns and would like to work closely with you as one of our neighbours to ensure that good working relationships can prosper.

To summarise:

- Markfield Art's aim is for safe, controlled activities that will have minimal impact on the local community
- Adequate controls and effective tried and tested systems are in place for proactive and effective management
- Competent people are in place to manage the premises

I hope that you are able to feel reassured by this response. Please do not hesitate to contact me if you have any queries or require further information. We would also like the opportunity to discuss this in person. Please feel free to contact P.M. Bacon on 07710 088947 to arrange a meeting.

Yours sincerely

Abhishek Beltharia

07896993830

MARKFIELD ARTS LTD

Regd office: suite 17789, lower Ground floor 145-157 St. John street EC1V4PW

DATE: 30TH OCT.2012

Dear Natascha Franklin,

I wish to respond to the representation that you have submitted in relation to the granting of a license for the above venue. Your representation refers to the following concerns, these being:

- Use of Alcohol
- Public Nuisance
- Noise
- Concerns for Markfield Park

We are duty bound by mandatory conditions to manage alcohol on site. We also have an alcohol management policy ourselves that prevents alcohol being supplied irresponsibly. It is plainly obvious that if the crime, disorder, anti-social behaviour, intimidation, threat to public safety, noise nuisance or disturbance that you have referred to, had occurred at our previous events, then it is quite clear that local residents would, and should, be opposed to this application en-masse. We would also expect both the Police and the Council's health and safety officers to object to the terms of the proposed licence if this was a real concern. We have worked closely with the Responsible Authorities to promote the licensing objectives and will continue to do so. It is clear that they are satisfied with the arrangements that we have put in place and there are no outstanding representations from these experts. There is no need for anyone in the local community to feel threatened. We have signage in place asking people to leave quietly and responsibly and, SIA security staffs are on duty to manage the area immediately around the venue and to encourage attendees to move on once the venue has closed. We have sufficient waste receptacles within the curtilage of the venue and will ensure that our SIA security personnel do not allow people to exit with drinking vessels or food packaging and encourage attendees to dispose of waste before they leave the site.

With regard to noise, again I must reiterate that you should not have been bothered by noise as a result of any of the previous events held by Markfield Arts and I'm sure we would have been informed if you had felt

the need to have made any complaints to the Council about any nuisance or unreasonable disturbance that you have suffered.

We are in dialogue with the Haringey Council Enforcement Response Team to install a noise-limiting device in the Venue and set a level approved by the response team prior to regulated entertainment taking place in conjunction with the premises license.

However, to reassure you further I can confirm that we have a noise management strategy, which involves monitoring any potential noise from the venue in the surrounding area and managing the sound at source within the venue. You really have no need to be concerned.

I have to say that I am reassured that you have not linked the Public nuisance of any sort with the Markfield Arts events.

I am sorry to hear that you have been disturbed; we have noticed Markfield Road and the surrounding area are very busy even on nights even when we are not holding events. In Markfield Park there have been two illegal events that have been held while we have had licensed event ourselves. I would think it would be impossible to distinguish if these people who disturbed you were going to our event. It is a little unfair to link all Public nuisances to the events in Markfield Arts.

Unfortunately these events you mentioned, you have not supplied us with specific dates so we cannot establish which event was ours. There are many illegal and unlicensed events taking place in the area and we find ourselves in unfortunate position of being blamed for everything negative what goes on in Markfield Park and adjacent areas. We ourselves went to Markfield Park after the illegal event and were disgusted by the mess that was left. I think we would agree events like this should be stopped .As for our events coursing litter and rubbish being left in Markfield Road or Park we put great efforts into this particular task. We clean the area thoroughly during and after every event in many cases cleaning the rubbish of other businesses and the general public, as we are fully aware that we are likely to be blamed for any rubbish left. If you see Markfield Road on a Monday morning when we have not been holding an Event you will notice a stark contrast.

You also write “ This is not a company interested in hosting arts events”. On the contrary we are very interested in hosting Art event and has hosted several so far and we are very much interested in showcasing local artistic talent. We are in dialogues with various local groups and production companies also we have had many local people coming to our events and all are of different colour, Shapes and sizes.

We have no desire to cause you undue concerns and would like to work closely with you as one of our neighbours to ensure that good working relationships can prosper.

To summarise:

- Markfield Art's aim is for safe, controlled activities that will have minimal impact on the local community
- Adequate controls and effective tried and tested systems are in place for proactive and effective management
- Competent people are in place to manage the premises

I hope that you are able to feel reassured by this response. Please do not hesitate to contact me if you have any queries or require further information. We would also like the opportunity to discuss this in person. Please feel free to contact P.M. Bacon on 07710 088947 to arrange a meeting.

Yours sincerely

Abhishek Beltharia

07896993830

This page is intentionally left blank

MARKFIELD ARTS LTD

Regd office: suite 17789, lower Ground floor 145-157 St. John street EC1V4PW.

DATE: 30TH OCT.2012

Dear Sasha Andrews,

I wish to respond to the representation that you have submitted in relation to the granting of a license for the above venue. Your representation refers to the following concerns, these being:

- Public Safety
- Inebriated People
- Noise
- Mess/Litter

We are duty bound by mandatory conditions to manage alcohol on site. We also have an alcohol management policy ourselves that prevents alcohol being supplied irresponsibly. It is plainly obvious that if the crime, disorder, anti-social behaviour, intimidation, threat to public safety, nuisance or disturbance that you have referred to, had occurred at our previous events, then it is quite clear that local residents would, and should, be opposed to this application en-masse. We would also expect both the Police and the Council's health and safety officers to object to the terms of the proposed licence if this was a real concern. We have worked closely with the Responsible Authorities to promote the licensing objectives and will continue to do so. It is clear that they are satisfied with the arrangements that we have put in place and there are no outstanding representations from these experts. There is no need for anyone in the local community to feel threatened. We will have signage-asking people to leave quietly and responsibly and, SIA security staff will be on duty to manage the area immediately around the venue and to encourage attendees to move on once the venue has closed.

The agreed maximum attendance of 450 will not cause disruption and congestion for residents. This attendance is no more than events that have been held by us in the past.

You also write " about inebriated people who collect late in night". I am sorry to hear that you are worried about the inebriated people on the street. I have to say that I am reassured that you have not linked the above concerns of any sort with the Markfield Arts events that have taken place in the past. You shouldn't be concerned about Public safety in the area as a result of this license application. The Police do not have these concerns and as a result, have not made a representation.

With regard to noise, again I must reiterate that you should not have been bothered by noise as a result of any of the previous events held by Markfield Arts and I'm sure we would have been informed if you had felt the need to have made any complaints to the Council about any nuisance or unreasonable disturbance that you have suffered. We are in dialogue with the Haringey Council Enforcement Response Team to install a noise-limiting device in the Venue and set a level approved by the response team prior to regulated entertainment taking place in conjunction with the premises license.

However, to reassure you further I can confirm that we have a noise management strategy, which involves monitoring any potential noise from the venue in the surrounding area and managing the sound at source within the venue. You really have no need to be concerned.

With regards to mess/litter, we have sufficient waste receptacles within the curtilage of the venue and will ensure that our SIA security personnel do not allow people to exit with drinking vessels or food packaging and will encourage attendees to dispose of waste before they leave the site.

As for our events coursing litter and mess being left in Markfield Road we can assure you that we put great efforts into this particular task, We have been cleaning Markfield Road thoroughly during and after every event in many cases cleaning the rubbish of other businesses and the general public, as we are fully aware that we are likely to be blamed for any rubbish left. If you see Markfield Road on a Monday morning when we have not been holding an Event you will notice a stark contrast.

We feel it is unjust that you elude to Markfield Arts having a negative impact on the surrounding areas. As a relatively new business in the area, we want nothing else but the positive promotion of the area and its surroundings.

Everything that you raise in your representation is what you 'believe' might happen if the venue is granted a licence and not what has actually happened. There have been over a dozen events held at this venue and run by the proposed licensee and to date, none of your fears have been realised. Please rest assured that the attendance numbers agreed in this proposed licence are no greater than those that have previously been held under Temporary Event Notices.

We have no desire to cause you undue concerns for your personal safety and would like to work closely with you as one of our neighbours to ensure that good working relationships can prosper.

To summarise:

- Markfield Art's aim is for safe, controlled activities that will have minimal impact on the local community
- Adequate controls and effective tried and tested systems are in place for proactive and effective management
- Competent people are in place to manage the premises

I hope that you are able to feel reassured by this response. Please do not hesitate to contact me if you have any queries or require further information. We would also like the opportunity to discuss this in person. Please feel free to contact P.M. Bacon on 07710 088947 to arrange a meeting.

Yours sincerely

Abhishek Beltharia

07896993830

This page is intentionally left blank

When answering this liaison line.

Stay calm and be polite at all times.

Follow this script

Answer the phone and say

Hello this Markfield Arts can I help you

Listen to the person, they may be annoyed so let them finish

Then say

Can I please take your name and phone number and a brief description of the issue?

Fill in the first four sections of liaison line log

When finished say

We are Very Sorry if we have disturbed you in any way, I will get a member of the premises management team to contact you as soon as possible to resolve this issue.

Thank you

This page is intentionally left blank

Dear resident,

Markfield Arts .

While every precaution has been taken By Markfield Arts to prevent sound or traffic issues impacting on the wider community it is recognised by the organisers that a point of direct contact will allow for the swift resolution of situations affecting the public.

The Markfield arts community liaison line shall be operation throughout any event and our staff will endeavour to answer any questions promptly and address any issues that may arise regarding any event.

Should any issue arise affecting you please contact Markfield Arts community liaison line on ----- stating;

- Your name and contact details (preferably a telephone number and your address)
- the nature of the issue
- the location of the issue

These details are recorded and shall only be used in the resolution of an issue relating to any event and will not be passed to a third party.

Market Arts is committed to the protection of the environment and the prevention of nuisance to the public.

Regards Markfield Arts Premises Management

This page is intentionally left blank

Markfield Arts Liaison Line Log

Name	Location	Contact	Time	Problem	Action Taken	Contacted by Event site Manager /Name	Time	Date

Notes

This page is intentionally left blank



SL2000 SOUND LIMITER

INSTALLATION INSTRUCTIONS & SETUP PROCEDURE

(See pages 3,4 & 5 for setup procedure)

Installation Guide

ALWAYS CONTACT A COMPETENT ELECTRICIAN IF YOU HAVE ANY DOUBTS ABOUT ELECTRICAL WIRING.

All wiring must be installed in accordance with IEE regulations and it is assumed that any persons attempting to fit the SL2000 kit are familiar with electrical Wiring protocols.

Refer to the SL2000 setup procedure later in this manual for connection details.

Installation

1. Find a suitable position for the SL2000 main unit and fix securely using the screw holes provided. This will usually be at a height of 2m or more above floor level. For smaller venues where a 2 gang socket outlet is sufficient the power supply can be obtained by replacing a socket on the ring main with the 45amp switch. In this case the SL2000 should be sited above the socket for ease of wiring. (Take care when fixing – there may be concealed cables.)
2. Find a suitable position for the microphone unit, avoiding locations that are too close to the noise source. In a typical venue, with the stage area at one end, the microphone should be positioned centrally, away from the stage at a minimum distance equal to the stage width. (See diagram below.) If there is more than one source of noise the microphone should ideally be positioned equidistant from each source. The microphone is connected to the main unit using single core screened cable. Try to avoid running the cable alongside any mains cables as this may affect the operation of the unit.

Ideal microphone position

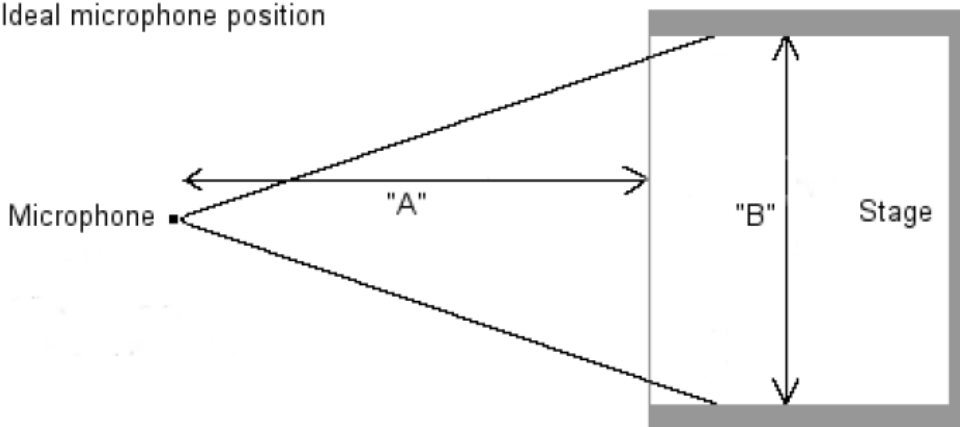

Distance "A" should ideally be equal to or greater than distance "B"

3. The remote indicator must be situated where it can be seen from the stage and can usually be positioned adjacent to the microphone. For ease of fixing double sided sticky pads can be used to avoid damaging the case. Connect the indicator unit to the main unit using the 4 core cable which can be clipped alongside the microphone cable. It is not important which colour cores are used as long as the cores are connected in the same order at both ends.

4. Connect the socket outlets to be monitored to the 2CN2 output connector at the main unit.

5. Finally, ENSURING THAT THE MAINS POWER HAS BEEN SWITCHED OFF, connect the 2CN1 terminals on SL2000 to the incoming mains power. (If the SL2000 is not wired back to the consumer unit on its own separately fused circuit, a 40 amp switch or a fused spur should be used to provide isolation and all surface mounted mains cables should be protected using 20mm conduit or trunking)

Note: Once installed it is important to ensure that musicians / DJs connect their equipment to the socket outlet which is controlled by the sound limiter and it is advisable to blank off any other power sockets in the vicinity of the stage to avoid confusion.

6. Adjustment

Take care when carrying out adjustments inside the SL2000 as live parts are exposed once the cover is removed.

A suitable noise source will be required with a sound level sufficiently high to carry out the following procedure. Standing outside of the venue, one person monitors the sound level using the sound pressure level meter. Another person inside the venue adjusts the volume until the maximum permissible level outside is just exceeded. (This must be agreed with the local environmental health office but is usually around 45db at the perimeter of a residential premises.) Referring to the SL2000 setup procedure earlier in this manual, adjust VR1 (and VR2 / VR3 if required) until the unit triggers. Connect the sound source to the Sound limiter controlled socket and with the key switch in the active position, ensure that power is disconnected from the sound source when the maximum permissible sound level is exceeded.

SL2000 NOISE POLLUTION CONTROL SYSTEM

SETUP PROCEDURE (See pages 1 & 2 for installation instruction)

1. INITIAL POWER UP

ON INITIAL POWER UP THE TIMER / POWER INDICATOR WILL FLASH AND THE OK INDICATOR LED WILL THEN ILLUMINATE. DUE TO CERTAIN INSTALLATION CONDITIONS THE T1 AND T2 INDICATOR LED'S MAY FLASH BEFORE RETURNING TO THE OK INDICATION LED. THIS UNIT IS NOW READY FOR ADJUSTMENT.

2. ADJUSTMENT

VR-1 (THE OVERALL MICROPHONE GAIN) SHOULD BE ADJUSTED* ACCORDINGLY TO DETERMINE THE DESIRED DECIBEL (dB) LEVEL REQUIRED TO TRIGGER THE UNIT.

3. FINE ADJUSTMENT

VR-2 HIGH FILTER ADJUSTMENT - THIS SHOULD BE ADJUSTED* IF YOU REQUIRE MORE OR LESS SENSITIVITY TO VOCALS ETC.

VR-3 LOW FILTER ADJUSTMENT -THIS SHOULD BE ADJUSTED' IF YOU REQUIRE MORE OR LESS SENSITIVITY TO LOW FREQUENCIES I.E. BASS.

* *ADJUSTMENT: ANTI-CLOCKWISE > LESS SENSITIVE / CLOCKWISE > MORE SENSITIVE.*

VR-5 TIMER ADJUSTMENT, NORMALLY SET TO 1 TO 1.5 SECOND INTERVALS GIVING AN OVERALL TIME OF APPROX 7 - 10 X 2 SECONDS. INTERVAL STEPS CAN BE SET BY OBSERVING THE FLASHING POWER INDICATOR LED ONCE ON PLUS ONCE OFF = 1 CLOCK PULSE. 5 PULSES = CUTOFF, 5 MORE PULSES TO AUTO RESET. 10 PULSES = 1 COMPLETE CYCLE.

AFTER BEING TRIGGERED AND THE VOLUME NOT BEING REDUCED, THE UNIT WILL THEN CUT OFF POWER FOR THE TIME YOU HAVE PRESET, AND THEN IT WILL RESET.

KEYSWITCH

THE KEYSWITCH HAS TWO SETTINGS, MONITOR AND ACTIVE.

MONITOR - ALLOWS THE UNIT TO ASSESS THE MUSIC BUT IT WILL NOT CUT OFF THE POWER IF THE PRESET LEVEL IS MET.

ACTIVE- ALLOWS THE UNIT TO MONITOR THE MUSIC AND THE POWER WILL BE CUT OFF IF THE PRESET LEVEL IS MET.

SL2000 NOISE POLLUTION CONTROL SYSTEM

TERMINAL CONNECTIONS

MAIN PANEL CONNECTIONS:

M1 - MICROPHONE +
M2 - MICROPHONE - (EARTH/SCREEN)

ENSURE SCREENED MICROPHONE CABLE IS USED TO CONNECT MIC TO M1 AND M2

NOTE: ON BOARD RELAY CONNECTIONS (J & K) CAN BE REGARDED AS AN ON/OFF SWITCH

(I.E. WHEN UNIT DISPLAYS GREEN OK LED, CONTACTS ARE CLOSED, WHEN RED OFF LED IS DISPLAYED CONTACTS ARE OPEN CIRCUIT. THE UNIT MUST BE POWERED UP AND THE MIC MUST BE CONNECTED TO ENSURE STEADY GREEN OK LED. OTHERWISE J - K IS OPEN CIRCUIT).

J - ON BOARD RELAY NORMALLY OPEN (WHEN UNIT IS NOT POWERED UP)

K - ON BOARD RELAY COMMON

J-K - IS USED TO SWITCH THE 30 AMP RELAY COIL / CONTACTOR COIL OR OTHER DEVICE DEPENDING ON INSTALLATION REQUIREMENTS.

NOTE: CONNECTIONS A-D ARE LOW VOLTAGE DRIVE OUTPUTS ONLY, AND ARE CONNECTED TO CORRESPONDING CONNECTIONS ON REMOTE LIGHT DISPLAY IF FITTED.

A - TRAFFIC LIGHTS 0 VOLT (COMMON)
B - TRAFFIC LIGHTS RED CHANNEL
C - TRAFFIC LIGHTS YELLOW CHANNEL
D - TRAFFIC LIGHTS GREEN CHANNEL

FA1 - FIRE ALARM + 24V DC INPUT FROM ANY EXISTING FIRE ALARM SYSTEM (USUALLY NEAREST BELL OR SIREN)
FA3 - FIRE ALARM NEGATIVE INPUT

P1 - EARTH

P2/P2A AND P3/P3A ARE 18V AC INPUT/OUTPUT CONNECTIONS FROM TXI SECONDARY MAINS TRANSFORMER. THE 18V AC AVAILABLE AT THESE CONNECTORS IS ALSO USED TO POWER LOW VOLTAGE AUXILIARY PANELS OR DEVICES. IE. REMOTE RELAYS ETC.

RELAY PANEL CONNECTION.

J - CONNECTS TO J ON MAIN BOARD. (ALREADY CONNECTED)
K - CONNECTS TO K ON MAIN BOARD (ALREADY CONNECTED)

P2 - CONNECTS TO P2 ON MAIN BOARD (ALREADY CONNECTED)
P3 - CONNECTS TO P3 ON MAIN BOARD (ALREADY CONNECTED)

SL2000 NOISE POLLUTION CONTROL SYSTEM

TERMINAL CONNECTIONS – Cont.

2CN1 30 AMP INPUT CONNECTOR:

L - 240 VOLT AC SUPPLY INPUT LIVE.
N - 240 VOLT AC SUPPLY INPUT NEUTRAL
E - INPUT EARTH.

NOTE: IT IS RECOMMENDED THAT THE SUPPLY TO CNI IS TAKEN FROM A SEPARATE 30 AMP ELCB/RCCD IN THE ON SITE CONSUMER UNIT.

2CN2 30 AMP OUTPUT CONNECTOR:

L - 240 VOLT AC CONTROLLED OUTPUT LIVE.
N - 240 VOLT AC CONTROLLED OUTPUT NEUTRAL
E - OUTPUT EARTH.

2CN3: LIVE, NEUTRAL AND EARTH CONNECTIONS TO TX I PRIMARY. (ALREADY CONNECTED)

TRAFFIC LIGHT REMOTE DISPLAY:

A, B, C, D CONNECT TO CORRESPONDING CONNECTORS ON MAIN PANEL (240 VOLT AC MAINS POWERED DISPLAYS SHOULD BE SUPPLIED VIA 5 AMP SWITCHED SPUR OR SIMILAR TO EURO CONNECTOR, LOW VOLTAGE CONNECTIONS, A, B, C, D STILL CONNECT TO A, B, C, D RESPECTIVELY ON MAIN PANEL)

THIS UNIT IS TO BE INSTALLED BY QUALIFIED PERSONS ONLY. ALL WIRING SHOULD CONFORM TO CURRENT REGULATIONS. ALL EARTH CONNECTIONS SHOULD BE MADE AND TESTED BEFORE USE. DISCONNECT SUPPLY BEFORE SERVICING.

SL2000 NOISE POLLUTION CONTROL SYSTEM

DIAGRAM OF CIRCUIT BOARDS

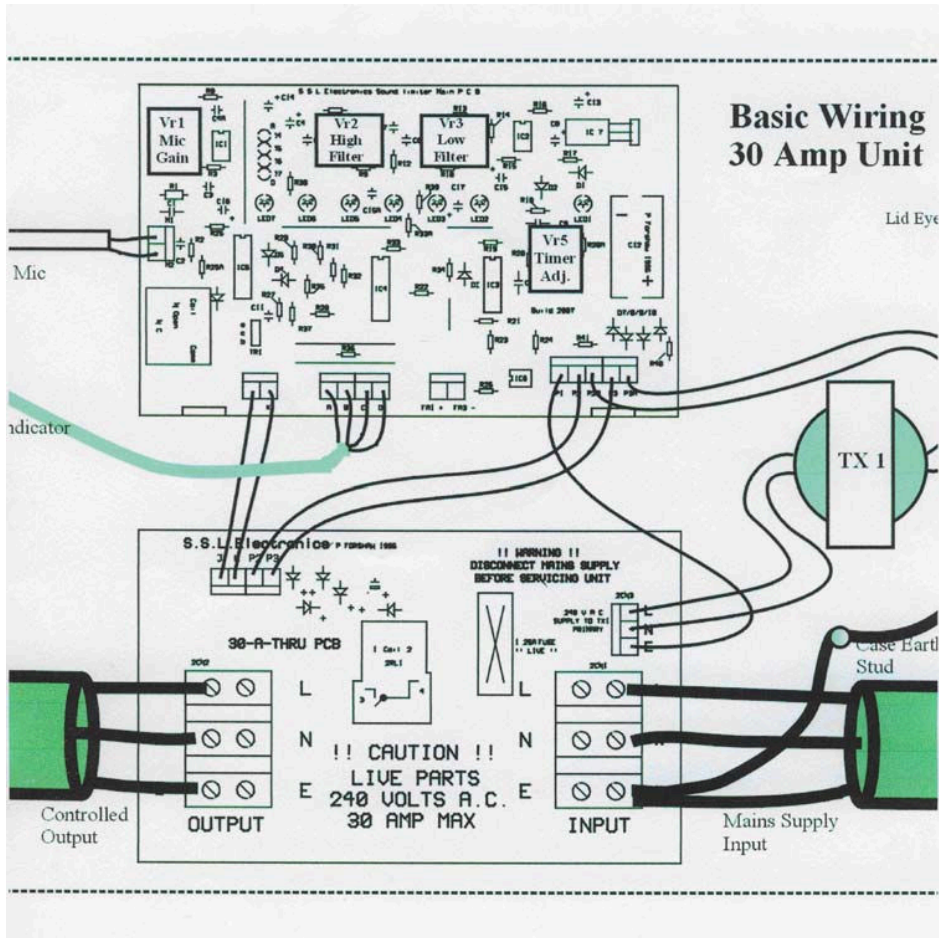

StageGear Ltd
Arreton PO30 3AQ
Tel: +44 (0)870 345 0352
Fax: +44 (0)844 357 6775
Email: sales@stage-gear.co.uk
Web: www.stage-gear.co.uk

Markfield Arts Sound Monitoring Log

Sound Monitoring								
Name	Location	Sound Level	Time	Action Required Y / N	Action Taken	Weather Conditions	Time	Date

Notes

This page is intentionally left blank

4.1 SOUND MANAGEMENT PLAN

All sound management will adhere to the conditions of the premises licence.

Some of our clients activities will involve amplified sound. Consideration will be given to the location of the systems on site in relation to the location of the nearest residential properties. The sound management plan is built on successful management plans and control measures from previous licenced events.

All sound systems shall be of an appropriate size in order to prevent nuisance to the wider community.

All sound systems will be staffed by competent personnel that shall report to production manager who shall report directly to the duty site manager and management.

A noise limiting devise will be installed and set to a level approved by Haringey Council's Enforcement Response team prior to regulated entertainment taking place in conjunction with the premises licence; be properly secured so it cannot be tampered with and independent of control by persons other than the licensee.

Sound system tests

The testing of the sound systems and the setting of output levels shall be carried out in conjunction with the guide lines set by Haringey Council

The test of sound systems will be scheduled prior to use in order to correct sound output levels and control any sound overspill and shall involve a monitoring team. The monitoring team shall be positioned both within the premises and at points close to the boundaries of the nearest residential properties.

Sound output levels

No noise shall be audible at the façade of any residential property in the vicinity

Adequate and competent staff shall be made available to monitor potential sound over-spill using an inaudibility test at a point close to the boundaries of the nearest properties at scheduled times.

This shall NOT apply to amplified broadcasts made in connection with evacuation of the premises in the event of fire or other emergency.

The sound monitoring team shall report directly to the duty site manager

Results from sound monitoring shall be recorded in a dedicated sound monitoring log book. The log shall contain;

- The name of the responsible individual
- The result of the sound sampling either- high /low or inaudible
- Any action required
- Weather conditions
- The time and date of the sound sampling.

4.2 SOUND MONITORING

The sound monitoring teams shall be comprised of competent and responsible persons with some experience of sound equipment.

The sound monitoring teams shall be provided with;

- A high visibility vest for offsite readings
- A sound monitoring log

Outside the premises

- monitoring at sample locations outside the premises on a hourly basis
- advise the duty site manager of any increases in sound output levels
- advise the duty site manager of any unwanted or stray frequencies (particularly low or bass frequencies)
- advise the duty site manager of any unwanted or unauthorised sound output (such as car stereo systems)
- Conduct themselves with due care and consideration for the residents of those properties close to the premises when conducting outside sampling.
- Communicate via mobile phone or text message if they are close to a property at noise- sensitive times

Inside the premises

The sound monitoring teams shall

- Conduct themselves in a safe and reasonable manor as representatives of Markfield arts
- Report increased sound output directly to the duty site manager
- Report unwanted frequencies directly to the duty site manager
- Report any other unwanted circumstances directly to the duty site manager

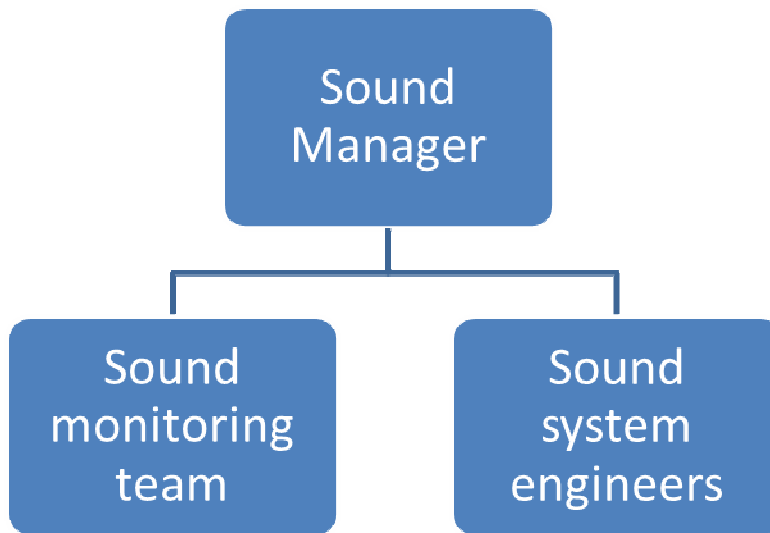

Hierarchy of sound management:

The Sound manager shall instruct the sound System engineers to adjust output as required and to prevent public nuisance.

This page is intentionally left blank

Details of the system are

NOISE POLLUTION CONTROL SYSTEM

The system automatically monitors and limits the sound output in venues such as clubs, public houses, wine bars etc, avoiding possible fines and closure of premises.

- Easy installation and operation
- Trigger level, reset time and frequency response are adjustable
- Automatic operation
- Fire alarm interface
- Remote microphone (supplied) monitors the sound level
- Built-in contactor with 30A switching capability
- Approved by Environmental Health Departments
- Robust steel case
- Remote status indicator available

This page is intentionally left blank